

ELLIPTIGO[®]

Owner's Manual

Welcome to the ElliptiGO® Family,

Thank you for purchasing an ElliptiGO bicycle. We have spent countless hours developing this fitness device and believe it to be the best form of low-impact exercise available. We hope you enjoy many years of healthy exercise and fun while riding it.

As you will see throughout this owner's manual, we value your safety. We have designed your bike to be a safe, fun and effective workout system. However, it is not a toy. Your ElliptiGO bike is an advanced piece of fitness equipment designed to be used for exercise by responsible riders. Improper use of this tool can result in destruction of property, serious injury, maiming, or death. For your safety, before your first ride you should read the entire owner's manual and pay particular attention to Chapters 2 and 3. This information is essential for understanding how to safely use and enjoy your machine. Although many of the components may look familiar to you, an ElliptiGO bike is very different from any other piece of fitness equipment or vehicle you may have used in the past. As a result, it is VERY IMPORTANT that you read and understand the information in this manual before riding it. Doing so could save your life.

In addition, we have safety and maintenance videos and information posted in the customer section of our website at www.elliptigo.com/support.html. If you have any questions or concerns, especially about how to safely use your ElliptiGO product, please contact us at any time at service@elliptigo.com.

Happy riding,
Brent and Bryan
ElliptiGO Co-Founders

Table of Contents

CHAPTER 1: IMPORTANT NOTIFICATIONS

CHAPTER 2: PRODUCT FAMILIARIZATION

- General Overview
- Terminology and Component Overview
- Proper Handling & Carrying Procedure
- Kickstand Operation
- Quick Release Clamping Systems
- Steering Columns
- Brakes
- Gearing Systems
- Chain Tension
- Wheels, Tires and Tubes
- Chain Keeper

CHAPTER 3: RIDING

- Basic Cycling Safety
- Adjusting the Fit
- Pre-Ride Safety Checklist
- Familiarization Ride
- Normal Riding
- Climbing and Descending Hills
- Riding in Adverse Conditions
- Competitive and Group Riding
- Stationary Trainers

CHAPTER 4: SERVICE AND MAINTENANCE

- Servicing ElliptiGO Products
- Maintenance Chart
- What Happens if I Damage My ElliptiGO Cycle?
- How Long Will My Bike Last?
- Torque Requirements for Screws and Fasteners
- Satisfaction Guarantee and Limited Warranty

IMPORTANT:

This owner's manual contains information regarding your components and how to do basic maintenance and service on your ElliptiGO® cycle. However, it is not intended to be a substitute for having your product serviced by a professional bicycle mechanic. YOU SHOULD HAVE YOUR ELLIPTIGO BIKE ASSEMBLED, MAINTAINED AND SERVICED BY A PROFESSIONAL BICYCLE MECHANIC.

CHAPTER 1: Important Notifications

DO NOT SKIP THIS SECTION!

Like running and cycling, riding an ElliptiGO® elliptical bicycle involves a real risk of serious injury, maiming and death. Each time you ride your ElliptiGO cycle, you are assuming this risk. We cannot stress enough how important it is to wear a helmet and proper clothing, know and follow the rules of the road, ensure your bike is in good working order before and during your ride, and to use caution when riding. To help minimize your risk of injury when riding your elliptical bicycle it is critical that you read and understand the contents of this manual and become familiar with operating and maintaining your bike before you head out on the road.*

To highlight some of the most important safety concerns, this manual contains many “Warnings”, “Cautions” and “Alerts” which are set out conspicuously in the manual.

Safety Warning

The following symbol: **▲WARNING!** (the safety designator together with the word WARNING!), calls attention to a potential hazard that, if not properly addressed or avoided, could cause serious injury or death.

Safety Caution

The following symbol: **▲CAUTION!** (the safety designator together with the word CAUTION!), calls attention to a potential hazard that, if not properly addressed or avoided, could cause property damage or an injury.

Damage Alert

The designation **ALERT!** calls attention to a situation which, if not properly addressed or avoided, could cause serious damage to your ElliptiGO bike and/or void your warranty.

As you will see, most of the Safety Warnings and Cautions contained in this manual relate to conditions that could result in the rider losing control of the ElliptiGO bike and suffering a fall. Every fall, regardless of the associated speed or cause, can result in serious injury or death for the rider, and injury to bystanders and property. As a result, a warning that indicates the rider may lose control and fall if a situation is not properly addressed or avoided may not also state that the resulting fall can cause serious injury or death. You should understand that this fact is always implied by the possibility of falling.

* No manual can address all of the potentially hazardous situations that could arise when riding a bike. As a result, we cannot provide guidance on how to safely ride the ElliptiGO bike in every circumstance. There are many unpredictable and unavoidable risks that are inherent in the sport of cycling. By choosing to ride a bike, you are voluntarily exposing yourself to these risks and are responsible for that choice.

CHAPTER 2: Product Familiarization

General Overview

The ElliptiGO® elliptical bicycle is a completely new kind of exercise device and performs differently from other machines you may have used in the past. If you treat it with respect, keep it maintained, and use it as intended, your ElliptiGO bike should provide you with many years of enjoyable outdoor exercise. **Before your first ride, you should read this manual in its entirety and get clarity on all aspects of the bike's performance, function, or design that you do not understand.** You should also consult your physician prior to beginning any exercise plan, including exercising on your ElliptiGO bike, to ensure that you are healthy enough for such exercise. You can reach our customer service department to get any questions answered by sending an email to: service@elliptigo.com.

Intended Use

ElliptiGO bikes are intended to be used on paved surfaces by individuals weighing less than 250 pounds for the purpose of enjoying outdoor exercise.

The use of an ElliptiGO elliptical cycle in any other manner is improper and falls outside of the scope of what the product was designed to do.

▲WARNING! ELLIPTIGO ELLIPTICAL BICYCLES ARE NOT TOYS AND ARE NOT DESIGNED FOR USE BY CHILDREN. The ElliptiGO bike does not meet the safety requirements for use by children, nor is it configured for use by children. Because it lacks the safety features

required for children's products, children can be seriously injured or killed while using the ElliptiGO bike. Consequently, DO NOT LET CHILDREN USE YOUR ELLIPTIGO BIKE. If you purchased your ElliptiGO product for a minor child, please contact ElliptiGO Inc. for a full refund immediately.

For use on Paved Surfaces

Our products have been optimized for riding on paved surfaces and there are certain aspects of our elliptical cycles that pose a risk to the rider if they are ridden "off-road" or on unpaved surfaces (including gravel, sand, or dirt). For example, the ElliptiGO bike's tires are not designed to be taken onto surfaces other than paved roads and will have degraded stopping and maneuvering abilities in those conditions. Similarly, for bikes with guide track systems, those systems must be kept free from debris to function properly. Riding on unpaved roads drastically increases the likelihood of getting debris into the track system which can damage the track system or cause the rider to lose control and suffer a fall. As a result, riding on unpaved roads falls outside the intended use of the ElliptiGO and could void your warranty.

Weight Restrictions

ElliptiGO bikes have a gross weight limit of 250 pounds for the rider and all accessories. By limiting the gross weight of the rider and accessories to 250 pounds combined, we have been able to create an affordable exercise device that delivers a high-performance fitness experience. This

weight limit was relied upon for every aspect of the design, from the components we selected, to the frame materials and configuration, to the thickness of the drive arms and steering column. Riders weighing more than 250 pounds fully-laden can subject the elliptical cycle to loads that exceed those to which we have tested our products. This could result in catastrophic failure of key components during regular riding.

In addition, even if the product does not appear to be damaged by a rider who weighs more than 250 pounds, the fatigue and stress caused by such a rider could greatly diminish the lifespan of many of the components we use. As a result, allowing your elliptical bike to be ridden by someone who exceeds 250 pounds **voids your warranty** and could result in a catastrophic failure of one or more components causing a rider to suffer a fall and be injured.

The Purpose of an ElliptiGO Elliptical Cycle

The purpose of an ElliptiGO elliptical cycle is to deliver a fun, low-impact, outdoor exercise experience. It is not to be used for trick riding and should never be used for stunts, jumps, wheelies, or other abusive maneuvers.

These will dramatically reduce its service life and could cause a catastrophic failure of one or more of its components, causing the rider to suffer significant injuries or death from a resulting fall.

▲WARNING! THE ELLIPTIGO BIKE HAS REAL LIMITATIONS IN WHAT IT CAN SUSTAIN. Misusing the bike can be extremely dangerous and void your warranty. Improper use of the bike, including riding with a combined

rider and accessories weight that exceeds 250 pounds or stunt, trick, or off-road riding, can cause a catastrophic failure of one or more components and result in the rider suffering a serious injury or being killed. DO NOT ENGAGE IN THESE OR OTHER ABUSIVE ACTIVITIES.

Terminology & Component Overview

3C and 8C Models

The picture below gives an overview of the components which make up the ElliptiGO® 3C and 8C products. These names will be referred to throughout the owner's manual.

- 1 FRAME
- 2 PRELOAD COLLAR
- 3 STEERING COLUMN
- 4 STEM
- 5 SHIFTER
- 6 GRIP
- 7 HANDLEBAR
- 8 BRAKE LEVERS
- 9 CONTROL CABLES
- 10 FRONT BRAKES
- 11 FORK
- 12 FRONT WHEEL
- 13 TIRE
- 14 FRONT QUICK RELEASE
- 15 KICKSTAND
- 16 REAR BRAKE
- 17 REAR WHEEL
- 18 INTERNALLY GEARED HUB
- 19 CHAIN
- 20 CRANK ARM
- 21 CHAINRING GUARD
- 22 CHAINRING
- 23 DRIVE ARM AXLE
- 24 DRIVE ARM
- 25 FOOT PLATFORM



Terminology & Component Overview

8S and 11R Models

The picture below gives an overview of the components which make up the ElliptiGO® 8S and 11R models. These names will be referred to throughout the owner's manual.

- 1 FRAME
- 2 FOLDING STEERING COLUMN
- 3 STEERING EXTENDER
- 4 STEM
- 5 SHIFTER
- 6 GRIP
- 7 HANDLEBAR
- 8 BRAKE LEVERS
- 9 CONTROL CABLES
- 10 FRONT BRAKES
- 11 FORK
- 12 FRONT WHEEL
- 13 TIRE
- 14 FRONT QUICK RELEASE
- 15 KICKSTAND
- 16 REAR BRAKE
- 17 REAR WHEEL
- 18 INTERNALLY GEARED HUB
- 19 CHAIN
- 20 CRANK ARM
- 21 CHAINRING GUARD
- 22 CHAINRING
- 23 DRIVE ARM AXLE
- 24 DRIVE ARM



Terminology & Component Overview

ELLIPTIGO Arc Model

The picture below gives an overview of the components which make up the ELLIPTIGO Arc product. These names will be referred to throughout the owner's manual.

- | | | | |
|----|---------------------------|----|-------------------------------|
| 1 | FRAME | 26 | CHAIN KEEPER |
| 2 | PRELOAD COLLAR | 27 | CRANK ARM |
| 3 | STEERING EXTENDER | 28 | FOOT PLATFORM |
| 4 | STEM | 29 | TOE CAGE (OPTIONAL ACCESSORY) |
| 5 | GRIP | | |
| 6 | HANDLEBAR | | |
| 7 | SHIFTER | | |
| 8 | BRAKE LEVERS | | |
| 9 | CONTROL CABLES | | |
| 10 | FRONT BRAKE | | |
| 11 | FRONT WHEEL QUICK RELEASE | | |
| 12 | FRONT WHEEL | | |
| 13 | TIRE | | |
| 14 | SWING ARM | | |
| 15 | DRIVE ARM | | |
| 16 | FOOT PLATFORM ASSEMBLY | | |
| 17 | CHAINRING GUARD | | |
| 18 | CHAINRING | | |
| 19 | CHAIN | | |
| 20 | REAR DERAILLEUR | | |
| 21 | CASSETTE | | |
| 22 | REAR WHEEL | | |
| 23 | REAR TIRE | | |
| 24 | REAR QUICK RELEASE | | |
| 25 | KICKSTAND (HIDDEN) | | |



Proper Handling and Carrying Procedure

C-Series and Models 8S and 11R

Picture 1 to the right demonstrates the proper method for handling, lifting or carrying your ElliptiGO® C-Series, 8S or 11R elliptical bike. The machine should be handled with one hand on the frame member which goes over the top of the rear wheel and the other hand on the steering column.

Picture 2 demonstrates an improper handling method which could result in bodily injury to the user.

⚠CAUTION! The ElliptiGO bike should never be picked up by any of the moving mechanism components such as the drive arms, crank arms, chain, chain ring or rear wheel. Doing so could cause your hand, wrist or arm to get pinched by the mechanism potentially causing a significant injury.



ELLIPTIGO® Arc Handling

Picture 1 to the right demonstrates the proper method for handling, lifting or carrying your ElliptiGO Arc. The machine should be handled with one hand on the frame and the other hand on the steering column.

Picture 2 demonstrates an improper handling method which could result in bodily injury to the user.

⚠ CAUTION! The ElliptiGO bike should never be picked up by any of the moving mechanism components such as the drive arms, crank arms, chain, chain ring or rear wheel. Doing so could cause your hand, wrist or arm to get pinched by the mechanism potentially causing a significant injury.



Kickstand Operation

C-Series and Models 8S and 11R

These ElliptiGO® products are equipped with a very stable double leg kickstand. To operate the kickstand, follow these steps:

1. Retracting the Kickstand - To retract the kickstand grab the steering column with one hand and the frame member which goes over the top of the wheel with the other hand. Lift the back of the frame while kicking the kickstand in the rearward direction.

2. Extending the Kickstand - To extend the kickstand grab the steering column with one hand and the frame member which goes over the top of the wheel with the other hand. Lift the back of the frame while kicking the kickstand in the forward direction.

ALERT! Do not stand on bike with the kickstand extended. Standing on the bike with the kickstand extended can cause a fall or damage your frame and kickstand, voiding your warranty.



ELLIPTIGO® Arc Kickstand

The ElliptiGO Arc is equipped with a single-leg kickstand. To operate the kickstand, follow these steps:

1. Retracting the Kickstand - To retract the kickstand, stand on the side closest to the kickstand. Grab the steering column with one hand and lean the bike away from you so that the kickstand no longer touches the ground. Then sweep the kickstand backwards with your foot, ensuring that it fully seats into the riding position, approximately horizontal with the ground.

2. Extending the Kickstand - To extend the kickstand, stand on the side closest to the kickstand. Grab the steering column with one hand, lean the bike slightly away from you and kick the kickstand down and forward.

ALERT! Do not stand on bike with the kickstand extended. Standing on the bike with the kickstand extended can cause a fall or damage your frame and kickstand, voiding your warranty.

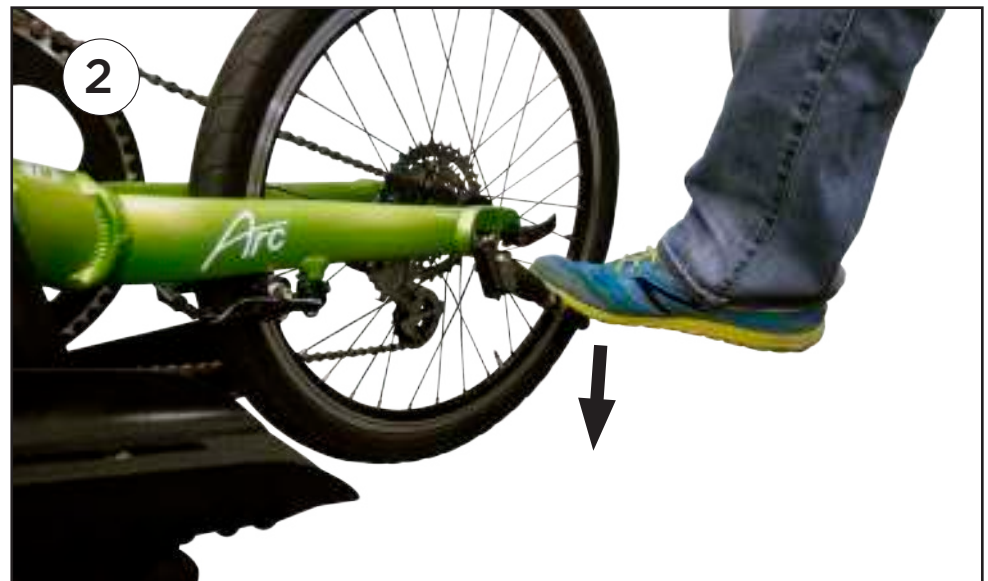

Quick Release Clamping Systems

Your ElliptiGO® elliptical cycle comes equipped with quick release clamping systems on the front wheel, the steering column and, on some models, the rear wheel. These are critical parts of any elliptical cycle and riding with an improperly adjusted quick release is very dangerous. You must understand how to use the quick release systems correctly to be able to operate your bike safely.

Quick release clamping systems can generate a significant amount of clamping force when used correctly. This force is needed to keep your wheels attached to the frame and your steering column locked in place while riding. If a wheel detaches or your steering column collapses while riding you will likely fall and suffer a serious injury.

Each quick release clamping system has three parts - a lever on one end, a nut on the other end, and a skewer in the middle. If properly adjusted, closing the lever generates a clamping force by pushing against the surface closest to the lever while simultaneously pulling against the surface nearest the nut. The lever has a cam-action system which can generate significantly more clamping force than using the lever or nut in a screw-like fashion can. The ideal clamping force for a quick release system on a bicycle is more than a typical person can generate using the lever as a screw, so it is important that you use the cam-action lever to operate all quick release systems.

⚠ WARNING! An improperly adjusted quick release lever can allow the steering extender to unexpectedly collapse or be removed from the bike or enable a wheel to become

loose or detach from the bike. Any of these situations could cause the rider to lose control of the elliptical cycle and suffer a serious injury or be killed. **IT IS CRITICAL THAT YOU UNDERSTAND HOW TO OPERATE THE QUICK RELEASE LEVERS AND THAT YOU CHECK THE SECURITY OF ALL QUICK RELEASE LEVERS BEFORE EVERY RIDE.**



Left: Location of quick release lever on front wheel.
Below: Locations of quick release levers on steering columns.



Adjusting the Quick Release Mechanism

The amount of clamping force for the quick release is controlled by the tension nut.

To increase the clamping force, turn the tension nut **clockwise** while holding cam lever fixed with the other hand.

To decrease clamping force, turn the tension nut **counter-clockwise** while holding cam lever fixed with the other hand.

A QUARTER TURN OF THE TENSION ADJUSTING NUT CAN MEAN THE DIFFERENCE BETWEEN A SAFE CLAMPING FORCE AND AN UNSAFE CLAMPING FORCE.

To check the clamping force, attempt to close the quick release lever. If you can close the quick release lever completely without using the fork, frame, or steering extender for leverage, and the lever closes without leaving a visible impression in your hand, then the quick release does not have enough clamping force. If, while using one hand on the fork, steering extender or frame for leverage, you cannot completely close the lever with the other hand, then the quick release has too much clamping force.

If there is too little clamping force, tighten the nut one-quarter turn and try clamping again. Repeat this until closing the lever requires grabbing the fork, frame or steering extender and leaves a mark in your hand. If there is too much clamping force, loosen the nut one-quarter turn and try clamping again. Repeat this until closing the lever requires grabbing the fork, frame or steering extender and the lever leaves a clear mark in your hand.

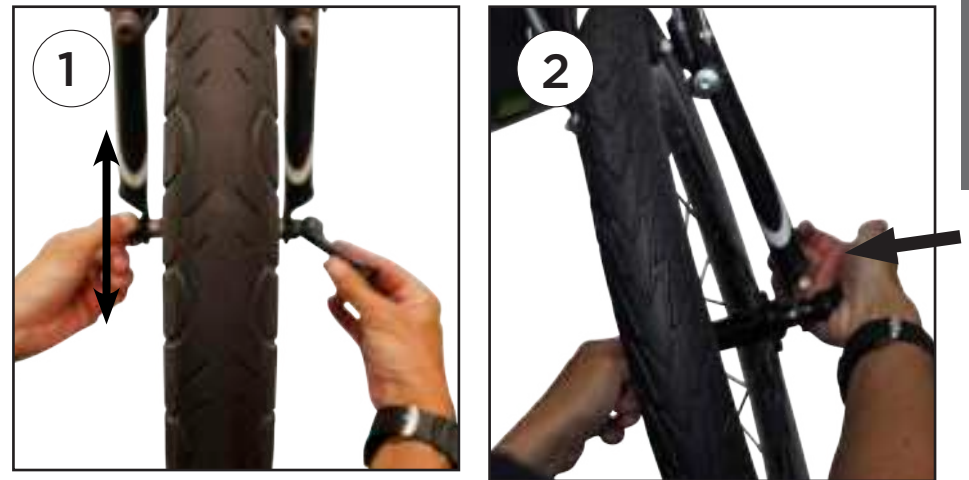

Steering Columns

C-Series and Arc models come equipped with a non-folding steering column. 8S and 11R models come equipped with a folding steering column. All steering columns have a storage position and a riding position that can be adjusted vertically to accommodate a wide range of riders.

Non-Folding Steering Column - Models 3C, 8C and Arc Model

The non-folding steering column consists of the following components:

1. The base
2. The steering extender quick release
3. The safety index pin
4. The steering extender



The Riding Position

When in the riding position, the steering extender is inserted to the correct depth in the base, the safety pin is fully inserted into the selected hole and the quick release lever is firmly closed. The correct depth is reached when the handlebar height is the most comfortable for the rider when riding and the “MAX EXTENSION” line is not visible above the base. This height is usually set so that the rider stands tall when riding with little to no weight on his/her hands or wrists.

To place the non-folding steering column into the riding position, follow these steps:

1. Place the bike on the kickstand.
2. Open the steering extender quick release.
3. Line up the safety groove on the side of the steering extender with the notch in the base and ensure that the control cables are in front of the steering column and not twisted around the steering extender.
4. Insert the steering extender into the base until it gently seats against the safety index pin.
5. Pull out the safety index pin with one hand and hold it while further inserting the steering extender into the base under until the desired handlebar height is reached. Ensure that the “MAX EXTENSION” line on the steering extender is not visible above the base.

⚠ WARNING! ENSURE THAT THE “MAX EXTENSION” LINE ON THE STEERING EXTENDER IS BELOW THE TOP OF THE BASE! Riding while the “MAX EXTENSION” line is above the base could result in the steering extender breaking during operation or being pulled out of the base, causing a fall. Never use an ElliptiGO product with the “MAX EXTENSION” line visible above the base.



6. Release the safety index pin and make fine movements on the steering extender until the pin aligns with the correct hole on the steering extender and springs completely back into place. Ensure that no red marks are visible on the pin.

⚠ WARNING! THE SAFETY INDEX PIN SHOULD BE FULLY SEATED SO THAT NO RED MARKINGS ARE VISIBLE ONCE THE STEERING HEIGHT IS SET. Failure to fully seat the index pin could result in the steering column collapsing during operation. This would likely cause the rider to lose control and fall.

7. Secure the steering extender quick release lever by grasping the steering extender for leverage and using enough force to leave an impression on your hand. See the Quick Release Clamping System section for details on closing quick release levers.

⚠ WARNING! Securing the quick release properly is critically important. Failure to do so could result in the steering extender collapsing or being removed unexpectedly while riding, causing the rider to fall. Make sure to follow the instructions set out in the Quick Release Clamping Systems section when closing a quick release lever.



The Storage Position

To place the non-folding steering column into the storage position, follow these steps:

1. Open the steering extender quick release.
2. Pull and hold out the safety index pin with one hand while removing the steering extender from the base collar with the other hand.
3. The extender, stem, and handlebar assembly can now be placed securely near the ElliptiGO® bike for storage.



Folding Steering Column - Models 8S and 11R

8S and 11R model ElliptiGO bikes come equipped with a steering column that telescopes to adjust the height of the riding position and folds for the storage position. The folding steering column consists of the following components:

1. The base
2. The collar
3. The column
4. The steering extender
5. The steering extender quick release
6. The steering collar quick releases



The Riding Position

When in the riding position, the column extends vertically up from the base, the steering extender is set to the correct depth in the column, the bottom of the collar is flush with the top flange of the base and set to the “LOCK” position, and all quick release levers are firmly closed. The correct steering extender depth is reached when the handlebar height is the most comfortable for the rider when riding and the “MAX EXTENSION” line is not visible above the base. This height is usually set so that the rider stands tall when riding with little to no weight on his/her hands or wrists.

To place the folding steering column into the riding position, follow these steps:

1. Place the bike on the kickstand.
2. Open both collar quick releases.
3. Slide the collar towards the handlebars along the steering column to clear the pivot.
4. Lift the steering column up into the vertical position so that it is in-line with the base.



5. Rotate the collar so that the arrow aligns with the “OPEN” marking on the right side of the steering base.
6. Slide the collar down over the pivot until the bottom of the collar sits flush on the flange of the base.

⚠ WARNING! ENSURE THAT THERE IS NO GAP BETWEEN THE BOTTOM OF THE COLLAR AND THE STEERING BASE FLANGE! Allowing a gap between the collar and the base could result in the collar rising above the pivot during a ride and the entire steering column collapsing unexpectedly. This would likely result in the rider losing control and suffering serious injuries from an ensuing fall.

7. Rotate the collar clockwise until the arrow on the collar aligns with the “LOCK” marking on the back of the steering column base.
8. Close both collar quick releases to lock the collar onto the steering column. The force applied to closing the lever should leave an imprint in your hand. See the section on Quick Release Clamping Systems above for details.
9. Open the steering extender quick release.

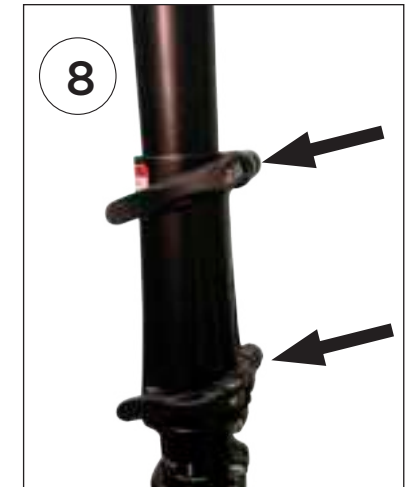

10. Slide the extender until the handlebars are at a desired riding position. Ensure that the “MAX EXTENSION” line on the steering extender is not visible above the base.

⚠ WARNING! ENSURE THAT THE “MAX EXTENSION” LINE ON THE STEERING EXTENDER IS BELOW THE TOP OF THE BASE! Riding while the “MAX EXTENSION” line is above the base could result in the steering extender breaking during operation or being pulled out of the base, causing a fall. Never use an ElliptiGO product with the “MAX EXTENSION” line visible above the base.

11. Close the steering extender quick release lever firmly, using the steering column for leverage. The force applied to closing the lever should leave an imprint in your hand. See the section on Quick Release Clamping Systems above for details.

⚠ WARNING! Securing the quick releases properly is critically important. Failure to do so could result in the steering extender collapsing or being removed unexpectedly while riding, causing the rider to fall and be seriously injured. Make sure to follow the instructions set out in the Quick Release Clamping Systems section when closing a quick release lever.

⚠ WARNING! The steering column is one of the most important safety features on ElliptiGO products. Before you ride, it is critical that you ensure it has been secured properly in the riding position and the quick release levers are fully closed with the appropriate amount of tension. Failure to properly secure the steering column into the riding position before riding can result in the unexpected folding of the steering column and failure to secure a quick release can result in the unexpected collapsing or removal of the steering column extender, any of which will likely cause the rider to fall and be seriously injured or killed.

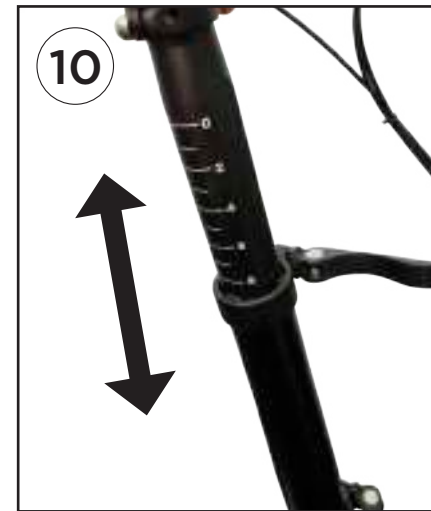

The Storage Position

To place the folding steering column into the storage position, follow these steps:

1. Open both collar quick releases.
2. Rotate collar 90 degrees counter-clockwise until index mark on collar lines up with "OPEN" mark on base.
3. Slide collar up above folding pivot.
4. Fold the steering column inward toward the center of the bike 90 degrees.
5. Slide the collar back so the groove on the collar engages the steering base.
6. While holding the collar tight against the steering base, close both collar quick-releases to lock into the storage position.

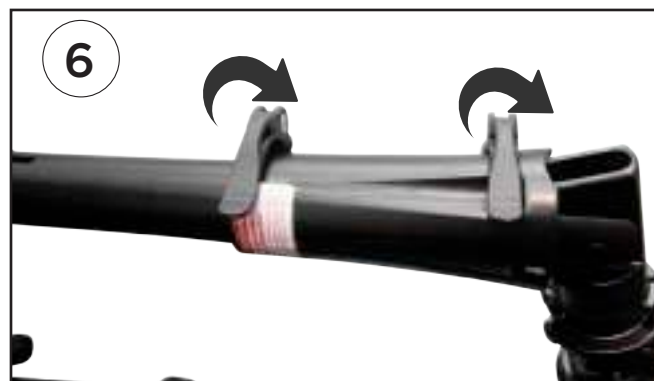
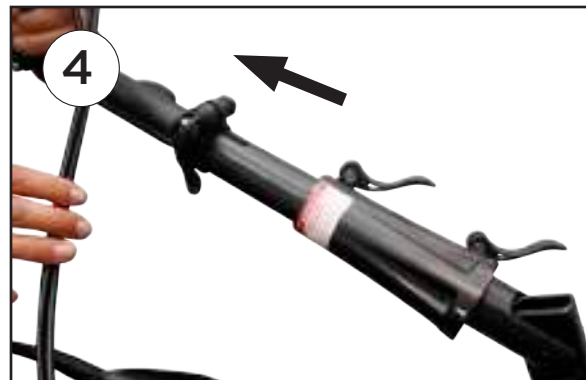

Brakes

Your elliptical bike comes equipped with front and rear rim brakes actuated by hand levers attached to the handlebars. One lever actuates the front brake and the other actuates the rear brake. The brakes are comprised of the following components:

1. Left brake pad
2. Left caliper
3. Brake noodle
4. Quick release bracket
5. Brake cable boot
6. Brake cable
7. Right caliper
8. Right brake pad

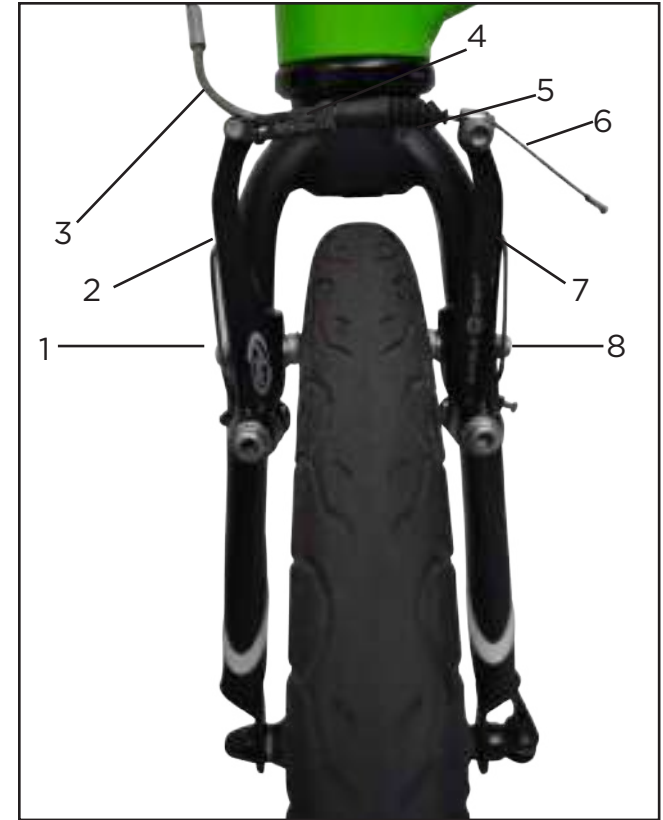

Each brake has a quick release mechanism that enables the corresponding wheel to be removed without deflating the tire. To open the brake quick release system, follow these steps:

1. Place the bike on the kickstand.
2. With one hand, squeeze the calipers together.
3. While holding the calipers, use the other hand to pull the brake noodle towards the hinge of the bracket (towards the left caliper). Use a finger of the hand squeezing the calipers to push the bracket cage down while simultaneously pulling up on the brake noodle so that the brake cable passes through the slot in the top of the quick release bracket.

4. Release the calipers so that they can spring open. To close the brake quick release system, follow these steps:

1. Place the bike on the kickstand.
2. With one hand, squeeze the calipers together.
3. With the other hand, pull the brake noodle towards the hinge of the bracket and slide the cable through the slot in the bracket. Then release the brake noodle so that it slides through the large hole at the edge of the bracket.
4. Release the calipers and test the brakes by actuating the corresponding brake lever on the handlebars and ensuring the close properly.

⚠WARNING! Ensure that the brake quick release system is properly closed and your brakes are functioning properly before riding your bike. If the brake quick release system is open or closed improperly, the brake will not function. Riding without operating brakes is extremely dangerous



and drastically increase the likelihood that the rider will collide with another object and suffer serious injury.

The correct way to apply the brakes under normal stopping conditions is to gently actuate both levers, having the rear brake engage the rear rim first and then slowly applying the front brake until it engages the front rim, then applying force to lever simultaneously to bring the bike to a smooth, controlled stop.

However, there is more to it than this, especially in emergency braking situations. Braking force is at its peak just before a wheel “locks up” and starts to skid. Once a wheel locks up, the braking force is greatly reduced and, more importantly, the bike becomes extremely difficult to control. The important skill to learn to optimize braking effectiveness is how to get to the maximum braking force quickly without locking up a wheel. This is best done by smoothly and efficiently increasing the braking force until maximum braking force is reached, as opposed to pulling the brakes to the point of maximum braking force immediately, which will likely result in overshooting on one or both brakes, causing tire lock up and skidding.

▲WARNING! Always apply the brakes in a smooth controlled manner. Start braking with the rear brake first, but always use both brakes to control speed. Applying the brakes too quickly or with too much force can result in a wheel “locking up” and the rider losing control and suffering a fall.

Be aware that as you slow down, inertia will cause your

body weight to move forward. The quicker you slow down, the quicker your body weight will shift forward. This effect makes avoiding rear wheel lock up even more challenging because one of the variables that determine when a wheel will lock up is the amount of weight supported by that wheel. The lighter the weight, the less force required to lock up the wheel. As a result, proper braking requires an adjustment for this shift in body weight as well as an active effort on your part to minimize this effect by consciously shifting your weight rearward during braking. However, usually to accommodate for this shift in body weight, you should apply more braking force to the front wheel and less to the rear wheel as the rate of deceleration increases and your weight is disproportionately borne by the front wheel. This weight distribution inequality becomes even more pronounced when braking downhill. The declined slope encourages a greater shift in weight towards the front wheel during deceleration, increasing the likelihood of a rear wheel lock up and requiring more braking force to be placed on the front wheel during an emergency stop.

Also, as discussed above, wet road conditions greatly reduce the stopping ability of an elliptical bike. Rim brakes rely on friction between the brake pad and the rim to slow rotation of the wheel. A wet rim will reduce the amount of friction that can be generated, especially at the initial stages of braking. Similarly, a wet road surface reduces the amount of traction for the tires, allowing the wheels to lock up more easily. These are two of the primary reasons why we discourage riding during wet conditions. If you must ride when the roads are wet, then the best way to adjust for this loss in stopping power is to slow down, to

pay more attention to potential hazards around you, and to begin braking much earlier than you otherwise would.

The best way to become effective at braking, especially emergency braking, is to practice. Seek out a safe, controlled environment with a well maintained, dry, level paved surface and practice braking for 30 minutes. This small investment of time can result in much improved braking skills, which could mean the difference between life and death on the road. In addition, always inspect your brakes and rims to make sure that they are clean and dry. Dirt or other debris on the surface of your rims or brakes can also reduce your stopping power and should be removed prior to riding.

Finally, brakes wear out by design. Regular use of your bike will require regular replacement of brake pads. Every time you inspect the bike, make sure your brakes and brake pads are in good working order and that your pads are not worn out. If any part of the pad has been worn away to the indicator groove, then it needs to be replaced. Also, if during an inspection a professional bicycle mechanic or ElliptiGO® technician indicates that you need new pads, have them replaced. Have your professional bicycle mechanic select an appropriate replacement pad, install it for you, and adjust the brakes so they function properly again.

Gearing Systems

Your ElliptiGO bike comes equipped with a gearing system that allows you to maintain a similar cadence across a variety of terrain. C-Series, 8S and 11R models come equipped with internally-gear hubs where the gearing system is inside the rear hub itself. Arc models come equipped with a set of gears attached to the rear wheel and a derailleur system that moves the chain manually from gear to gear. Both of these systems will require periodic adjustment to function properly. Follow the instructions below to adjust the gearing system on your model.

Adjusting the Internally-Geared Hub on the 3C Model

1. Place your bike on the kickstand.
2. Do a visual inspection of your shifter cable. Make sure it is fully seated in the gear shift housing. Then follow it through the frame to ensure it is not pinched in the mudguard and is seated properly in the frame bosses. Finally check to make sure it is seated correctly in the hub cable bracket that attaches to the hub.
3. Use the gear shifter to shift up into 3rd gear and then down into 2nd gear.
4. Move to the rear of the ElliptiGO and check the location of the yellow arrow relative to the yellow lines on the outside of the hub. The point of the arrow should be in the middle of the yellow lines.
5. If the point of the arrow is not in the middle of the two yellow lines, you will need to adjust it using the barrel adjuster on the gear shifter.
6. Stand on the right side of the bike facing towards the bike. If the point of the arrow is above the yellow lines, rotate the barrel adjuster clockwise (forward towards the front wheel) one full turn. If the point of the arrow is below the yellow lines, rotate the barrel adjuster counterclockwise (back towards the rear wheel) one full turn.
7. Now shift into 3rd gear and then back to 2nd gear and check the alignment. If the point of the arrow is still not in the middle of the yellow lines, repeat steps 6-7 until it is.

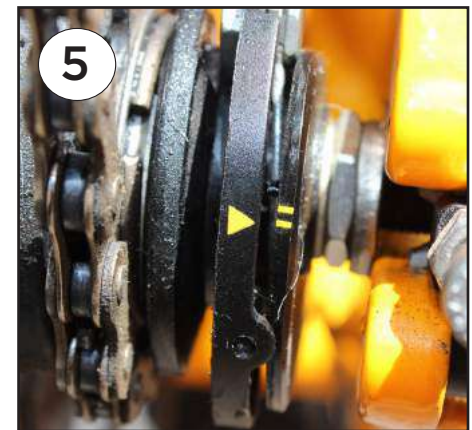
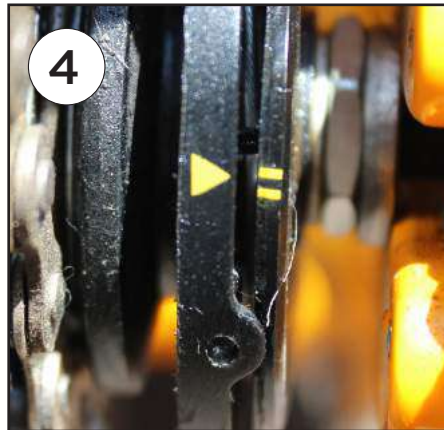

Adjusting the Internally-Geared Hub on the 8C Model

1. Place your bike on a flat surface and stand it up on the kickstand.
2. Do a visual inspection of your shifter cable. Make sure it is fully seated in the gear shift housing. Then follow it through the frame to ensure it is not pinched in the mudguard and is seated properly in the frame bosses. Finally check to make sure it is seated correctly in the hub cable arm that attaches to the hub.
3. Your bike is equipped with one of two versions of the Shimano Alfine 8-speed hub. The hub adjustment process to follow will depend on which version you have. To determine which version you have, stand between the front and rear wheel (as if you were riding) and look at the gear indicator window on the handlebars above the gear shifter levers. If the left-most number is a 1, then follow the steps below labeled 4a, 5a, 6a, and 7a. If the left-most number is an 8, then follow the steps below labeled 4b, 5b, 6b and 7b.

For 8-speed hubs where the left-most number in the gear indicator window is a 1:

- 4a. Use the gear shifter to shift down into 1st gear, then up to 5th gear, and then down into 4th gear. Move to rear of the bike and find the small display window with the two yellow lines. If the two yellow lines are aligned then no further action is needed. If they are not aligned, continue with the alignment procedure set forth below.

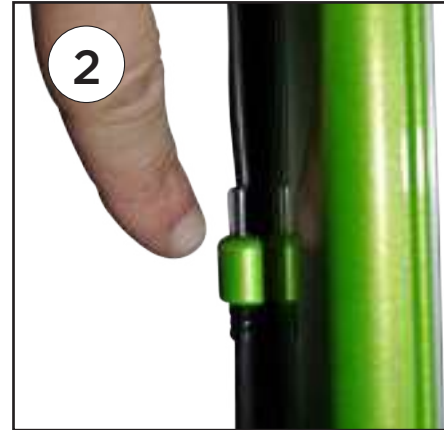

- 5a. Stand on the right side of the bike facing towards the bike. If the outside (away from the hub) line was above the inside line, rotate the barrel adjuster on the handlebar counterclockwise (back towards the rear wheel) one full turn. If the outside line is below the inside line, rotate the barrel adjuster clockwise (forward towards the front wheel) one full turn.
- 6a. Use the gear shifter to shift down into 1st gear, then up to 5th gear, and then down into 4th gear.
- 7a. Check the alignment of the yellow lines. If they are still not aligned, repeat steps 5-7a until they are aligned.



For 8-speed hubs where the left-most number in the gear indicator window is an 8:

- 4b. Use the gear shifter to shift up into 8th gear and then down into 4th gear. Move to rear of the bike and find the small display window with the two yellow lines. If the two yellow lines are aligned, like in photo 4b then no further action is needed. If they are not aligned, continue with the alignment procedure set forth below.
- 5b. If the outside line is below the inside line, rotate the barrel adjuster clockwise (forward towards the front wheel) one full turn. Stand on the right side of the bike facing towards the bike. If the outside (away from the hub) line is above the inside line, rotate the barrel adjuster on the handlebar counterclockwise (rearward towards the rear wheel) one full turn.
- 6b. Use the gear shifter to shift up to 8th gear and then down into 4th gear.
- 7b. Check the alignment of the yellow lines. If they are still not aligned, repeat steps 5-7 until they are aligned.

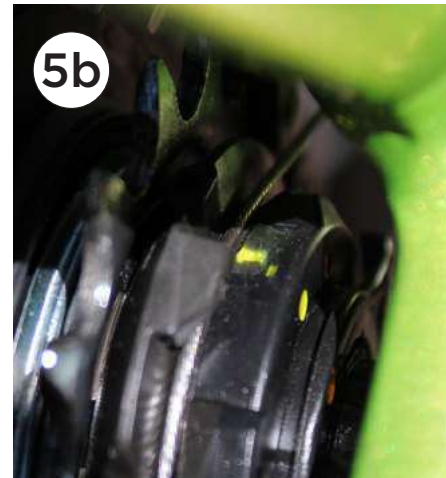
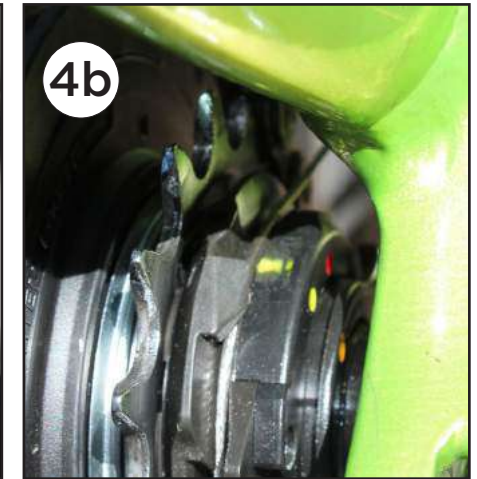

Adjusting the Internally-Geared Hub on the 11R Model

1. Place your bike on the kickstand.
2. Do a visual inspection of your shifter cable. Make sure it is fully seated in the gear shift housing. Then follow it through the frame to ensure it is not pinched in the mudguard and is seated properly in the frame bosses. Finally check to make sure it is seated correctly in the hub cable arm that attaches to the hub.
3. Shift up to 11th gear then down to 6th gear.
4. Move to rear of your bike and check the alignment of the two yellow lines by the hub. If they two lines are aligned, like in photo 4, then no further action is needed.
5. Stand on the right side of the bike facing towards the bike. If the outside (away from the hub) line is above the inside line, rotate the barrel adjuster on the handlebar counterclockwise (back towards the rear wheel) one full turn. If the outside line is below the inside line, rotate the barrel adjuster clockwise (forward towards the front wheel) one full turn.
6. Use the gear shifter located to shift up to 11th gear and then down into 6th gear.
7. Check the alignment of the yellow lines. If they are still not aligned, repeat steps 5-7 until they are aligned.

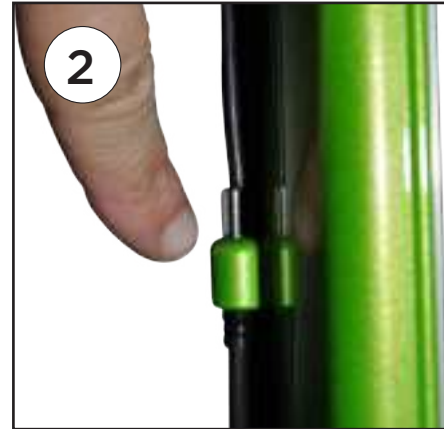

Adjusting the Derailleur System on the Arc Model

1. Place your bike on the kickstand.
2. Do a visual inspection of your shifter cable. Make sure it is fully seated in the barrel adjusters on both the shifter and the rear derailleur.
3. With the bike leaning on the kickstand so the rear wheel is off the ground, turn the foot platform by hand while shifting from eighth gear to first and back to eighth.
4. Take note if the shifting hesitated while shifting in either direction.
5. If the shifting was slow moving from eighth to first, turn the barrel adjuster on the derailleur clockwise one half turn and recheck the shifting.
6. If the shifting was slow moving from first to eighth gear, turn the barrel adjuster on the derailleur counter-clockwise one half turn and recheck the shifting.
7. Repeat this sentence with: Repeat steps 3 - 6 until the shifting is smooth in both directions.



Gear Selection

Your ElliptiGO bike comes equipped with gears, a “trigger shifter” control mechanism and a numbered gear selection indicator that indicates the current selected gear. The lower the gear, the easier it is to pedal and the shorter the distance traveled per rotation of the crank arms. Conversely, the higher the gear, the harder it is to pedal and the further the distance traveled per rotation of the crank arms.

The trigger shifter systems provide an effective means for changing gears. For Arc, 8C, 8S and 11R models, the mechanism has two levers, a thick “thumb lever” towards the rear of the system and a thinner “finger lever” towards the front of the system. To shift into a lower gear on the Arc, 11R and some 8C models, push the thumb lever forward until it stops and then release it. To shift all 8S and some 8C models into a lower gear, push or pull the finger lever until it stops and then release it. If you have an 8C, to determine how your shifter functions simply push the thumb lever two to three times while watching the gear indicator and observe whether it shifts into higher or lower gears. You should be able to hear the mechanism working as you shift and see the gear selection indicator line move from gear to gear.

The 3C shifter uses an upper and lower thumb lever. To shift into a higher gear, push the upper lever forward until it stops and then release it. To shift into a lower gear, push the lower lever forward until it stops and then release it. Again, you should be able to hear the mechanism working as you shift and you can watch the gear selection indicator line move from gear to gear.

⚠️WARNING! Always ensure that the lever has been completely depressed before releasing. Failure to completely depress the lever can result in a shifting failure that can change the pedaling experience unexpectedly. This can cause the rider to lose control and suffer a fall. It is important during your familiarization ride to understand the pedaling experience in each gear and to get comfortable assessing which gear is appropriate for the different speeds at which you will be traveling during a ride.

Chain Tension

Over time, the chain on your bike will stretch and become loose. A loose chain can cause slipping gears, can accelerate the wearing down of the teeth on the chainring and sprocket and can fall off the chainring while riding. You should check your chain periodically and expect to replace it about every six to twelve months. The Arc model comes equipped with a chain tensioner that will absorb this stretching over time. The chain tension on the 3C, 8C, 8S and 11R models will need to be manually tensioned periodically. In between replacements, you will likely need to add tension to the chain as it stretches.

To adjust the chain tension on the 3C, 8C, 8S and 11R models, follow these steps:

1. Place the bike on the kickstand.
2. With the 15mm wrench, loosen both axle nuts.
3. With the 10mm wrench, loosen the chain tension nut.
4. Using the 5mm Allen wrench, turn each chain tension screw clockwise to slide the rear wheel forward in the dropouts. Do this evenly on both sides to keep the wheel centered.
5. Once you have desired tension, tighten the axle nuts with the 15mm wrench.
6. Tighten the chain tension nut with 10mm wrench.
7. Check for binding in the chain by rotating the drive arms and testing if the chain is too tight. When properly tensioned, there should be about one inch of “play” in the chain. If the chain has less than that, loosen the axle nuts and loosen the chain tension screws by rotating them counterclockwise until the chain has the proper tension. Then repeat steps 5 - 7.



Wheels, Tires and Tubes

Your ElliptiGO® bike comes equipped with a 20” spoked wheelset, high-pressure clincher-style tires and presta-valve tubes. These comprise the system that actually connects the bike to the ground, so it is important that you understand how they function and how to take care of them.

Wheels

Your wheels are a critical part of your bike. You should pay particularly close attention to the following parts of your wheels:

True

To perform safely on the road, your wheels must be “true.” A wheel is true when all of the spokes are tensioned such that there is no side to side wobble when the wheel is rotated about the hub. Truing a wheel requires special tools and skills and should always be done by a trained bicycle mechanic.

⚠️WARNING! A wheel that is not true can present a very dangerous situation because it interferes with the proper functioning of the brakes. It requires skill and proper tools to correctly true a wheel. As a result, we strongly recommend taking the ElliptiGO bike to a professional bicycle mechanic to have your wheel trued prior to riding. Riding on a wheel that is not true could cause you to lose control and suffer a fall.

Rim Surface

Your rim should have no visible signs of wear and be free from damage, including cracks, ruts or chips. To check for wear, find the wear indicator groove on the rim and ensure that it is still easy to feel depth in the groove below the rim surface. If you cannot locate the groove, DO NOT RIDE your bike. Instead contact service@elliptigo.com or take your bike to a certified bicycle mechanic.

⚠️WARNING! Never ride on a rim that is worn below the wear indicator groove, a rim that is bowed, or a cracked rim. Not only does a worn, bowed or cracked rim reduce stopping power, but it will eventually break, likely without warning. If your rim breaks it will almost certainly cause the tire to come loose and the rider to suffer serious injuries or death from a resulting fall.

Spokes

Each spoke plays a critical role in providing wheel strength, performance and alignment. Loose spokes and over-tightened spokes can both present dangers to the rider. Ensuring that your spokes are in proper tension requires special tools and skills and should always be done by a trained bicycle mechanic.

Quick release clamping system

The front wheel on all ElliptiGO models and the rear wheel on Arc models are attached to the bike by quick release clamping systems. It is critical to use these systems properly when attaching a wheel to your bike. Before attaching or removing a wheel that includes a quick release clamping system, you should closely read the section above entitled Quick Release Clamping Systems.

▲WARNING! An improperly adjusted quick release can allow the front or rear wheel to become loose or detach from the bike. If a wheel detaches from the bike while you are riding it, you will lose control and suffer a serious injury or be killed. IT IS CRITICAL THAT YOU UNDERSTAND HOW TO OPERATE THE QUICK RELEASE LEVERS AND THAT YOU CHECK THE SECURITY OF EACH QUICK RELEASE SYSTEM EVERY TIME YOU RIDE THE BIKE.



Front Wheel Installation

To install the front wheel follow these steps:

1. Place the bike on the kickstand.
2. Check the rotational direction arrow on the tire and ensure it is pointing forward.
3. Open the quick release lever on the front wheel.
4. Insert the wheel into the fork. Press down on the head tube to ensure the quick release skewer is properly seated in the fork dropouts. Adjust the tension nut to ensure there is enough clearance for the wheel to seat properly.
5. Tighten the tension nut and close the quick release lever so that there is appropriate clamping force as described in the Quick Release Clamping Systems section above.
6. Once the quick release has been adjusted, open the lever. Apply downward pressure to the frame and fork with the wheel resting on the ground so the wheel properly seats inside the fork dropouts. While still pressing down with one hand, use the other hand to close the quick release lever with the proper amount of force.
7. Close the brake quick release. See the Brakes section above for detailed instructions on closing your brake quick release system.
8. Rotate the wheel while looking and listening for a rubbing brake pad. If rubbing is present, open the quick release and re-seat the wheel by repeating steps 6 - 8. IF BRAKE RUBBING PERSISTS DO NOT RIDE, instead have your bike inspected by a professional bike mechanic or ElliptiGO technician.



▲WARNING! If your rims are damaged, cracked or worn out, or brake rubbing persists, **DO NOT RIDE**. Instead, consult a bicycle mechanic or contact ElliptiGO® Customer Service.

Front Wheel Removal

To remove the front wheel, follow these steps:

1. Place the bike on the kickstand.
2. Open the brake quick release. See the Brakes section above for detailed instructions on opening your brake quick release system.
3. Open the quick release lever on the front wheel. Loosen the tension nut with one hand while holding the quick release lever fixed with the other hand. For details on operating the quick release, see the Quick Release Clamping System section above.
4. Remove the front wheel.



Rear Wheel Removal - C-Series, 8S, 11R Models

To remove the rear wheel, follow these steps:

1. Place the bike on the kickstand.
2. Open the rear brake quick release. For detailed instructions see the Brakes section above.
3. If you have a 3C, shift into 3rd gear. If you have an 8S, use the finger lever to shift into 1st gear. If you have an 11R, use the finger lever to shift into 11th gear. If you have an 8C where actuating the finger lever INCREASES gears, use it to shift into 8th gear. If you have an 8c where actuating the finger lever DECREASES gears, use it to shift into 1st gear. Grab the cable housing and pull it out of hub shifter bracket. The cable should now be free from the rear wheel.
4. Disconnect the shifter cable from the hub by grabbing the cable housing and pulling it out of the hub shifter bracket. The cable should now be free from the rear wheel.
5. Using a 3mm Allen wrench, remove the both chain tensioner assemblies from the frame.
6. Loosen both wheel nuts using a 15mm wrench.
7. Slide the rear wheel backwards out of the wheel brackets of the frame while removing the chain from the hub sprocket.

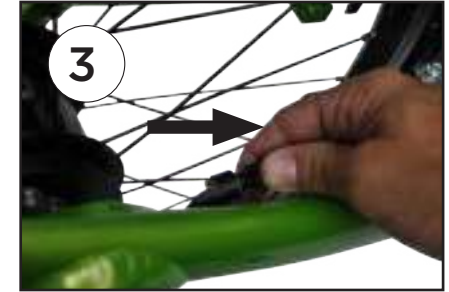

Rear Wheel Removal – Arc Model

To remove the Arc rear wheel, follow these steps:

1. Place the bike on the kickstand.
2. While standing on the right side of the bike, lean the bike towards the kickstand to lift the rear wheel off the ground slightly. Grab the foot platform and rotate the drive arm forward while shifting into 8th gear (the smallest cog on the cassette).
3. Open the rear brake quick release. See the Brakes section above for detailed instructions on how to open your brake quick release system.
4. Open the quick release lever on the rear wheel axle. Loosen the tension nut by turning it counterclockwise while holding the quick release lever still. Continuing loosening the tension nut until there is enough space for the wheel to detach from the bike.
5. Lean the bike gently on the kickstand to provide enough space between the wheel and the ground for the wheel to drop out of the frame. Push the rear wheel down and away from the frame. Lifting the bike higher off the ground may facilitate this process.
6. Remove the chain from the cassette so the wheel is completely free from the bike.



Rear Wheel Installation - C-series, 8S, 11R

To install the rear wheel follow these steps:

1. Place the bike on the kickstand.
2. Install rear wheel into the horizontal slots of the frame wheel brackets and ensure:
 - a. The toothed washer engages the slot as shown.
 - b. The cable bracket is oriented horizontally forward as shown.
 - c. The chain is around the sprocket as shown.
3. Loosely tighten the wheel nuts. The nuts should be loose enough so that the wheel can still slide in the wheel bracket when tensioning the chain.
4. Install the left and right chain tensioner assemblies. Torque to 2-3 Nm.
5. Using the chain tensioners, adjust the wheel so that it is centered in the frame and the chain is tight but not binding. For proper chain tensioning, please see Chain Tension Section.



6. Close the brake quick release. See the Brakes section above for detailed instructions on closing your brake quick release system.

⚠WARNING! Always check to ensure that the brake quick release system is properly closed before riding your bike. If the brake quick release is not in the closed position, the brake will be inoperable. Inoperable brakes are extremely dangerous and drastically increase the likelihood that the rider will collide with another object and suffer serious injury or death.

7. Tighten both wheel nuts to 30 N-m using a 15mm wrench.

⚠WARNING! During riding, the rear wheel is subject to a significant amount of force that is transferred through the chain to the rear cog. Failure to properly secure the wheel nuts could result in them becoming loose over time. If the nuts become loose, they could cause the wheel to move unexpectedly and contact the brakes or frame. This could cause the rider to lose control and suffer a fall. Make sure you check these nuts before every ride and ensure they are tightened to 30 N-m.

8. Install shifter cable back into the hub.
 - a. If you have a 3C, shift into 3rd gear. If you have an 8S, use the finger lever to shift into 1st gear. If you have an 11R, use the finger lever to shift into 11th gear. If you have an 8C where actuating the finger lever INCREASES gears, use it to shift into 8th gear. If you have an 8C where actuating the finger lever DECREASES gears, use it to shift into 1st gear.



- b. With one hand rotate the spring loaded shifter pulley clockwise, while hooking the shifter cable into the groove on the pulley with the other hand.

Spin the wheel to ensure the wheel spins freely, if it rubs, follow steps 5-8 to re-align the rear wheel.

⚠WARNING! If your rims are damaged, cracked or worn out, or brake rubbing persists, **DO NOT RIDE**. Instead, consult a bicycle mechanic or contact ElliptiGO® Customer Service.

Rear Wheel Installation - Arc Model

To install the rear wheel on the Arc model, follow these steps:

1. Place the bike on the kickstand.
2. Ensure the gear selection lever is in 8th gear.
3. While pulling the derailleur rearward to create space, guide the ends of the quick release skewer into the corresponding dropouts on the frame.
4. Seat the wheel fully in the dropouts and ensure that it is centered in the frame.
5. Close the quick release lever. Follow the detailed instructions set forth in the Quick Release Clamping Systems section above.

⚠ WARNING! Securing the rear wheel quick release properly is critically important. An improperly adjusted quick release can allow the rear wheel to become loose or detach from the bike. If the rear wheel detaches from the bike while you are riding it, you will lose control and suffer a serious injury or be killed. Make sure to follow the instructions set out in the Quick Release Clamping Systems section when closing a quick release lever. Make sure to check the security of your quick release levers before each ride.

6. Reattach the rear brakes. Follow the detailed instructions in the Brakes section above.

⚠ WARNING! Ensure that the brake quick release system is properly closed and your brakes are functioning properly before riding your bike. If the brake quick release system is open or closed improperly, the brake



will not function. Riding without operating brakes is extremely dangerous and drastically increase the likelihood that the rider will collide with another object and suffer serious injury.

7. Check that the chain is routed properly and the derailleur is functioning correctly by leaning the bike against the kickstand to lift the rear wheel off of the ground and then grabbing the foot platform with your hand and using it to rotate the drive arm forward while slowly shifting through the gears.



Tires

ElliptiGO products come equipped with high-pressure, unidirectional, clincher-style tires. These tires have a finite lifespan that depends on, among other things, rider weight, how well you maintain the tire pressure, the kind of riding that you do and the surfaces upon which you ride. As a result, there is no hard and fast rule regarding how long your tires will last.

It is important that you maintain the correct tire pressure in your tires. The maximum pressure is listed on the sidewall of the tires. We recommend riding at 90 - 95% of the maximum tire pressure. Use a floor pump with an air pressure gauge to inflate the tire to the correct pressure.

⚠️WARNING! Always check your tire pressure before riding. Underinflated or overinflated tires pose serious risks including loss of traction, blowouts, and buckling while cornering. Any of these situations could cause the rider to lose control and suffer a fall.

⚠️WARNING! Never inflate a tire beyond the maximum pressure - this can cause the tire to explode off of the rim and injure you or a bystander.

Before you ride, do a thorough visual inspection of the front and rear tires. Make sure there are no tears, cracks, or impregnated debris in the sidewall or along the tire tread. Ensure that the tread is not worn out and that the bead wire at the bottom of each sidewall is securely seated inside the rim. Look for bulging along the sidewall or tire tread. If you see any tears, cracks, bulging, or excessive wear, **DO NOT RIDE THE BIKE**. Instead, take your bike to a shop to have a new tire installed.

⚠️WARNING! Always check both tires before riding. Damaged or excessively worn tires increase the likelihood of experiencing a blowout, unseating of a tire, or sustaining a flat during a ride. Any of these situations could cause the rider to lose control and suffer a fall.

Finally, make sure that your tire is attached in the correct orientation. On the sidewall, locate the unidirectional symbol consisting of an arrow and the word “Drive” or “Rotation.” When the wheel is rotated so that the arrow is at the highest point during the rotation, the arrow should be pointing in the forward direction of travel. If, when the arrow is at the top of the wheel, it is pointing towards the rear of the bike, either the tire or the wheel is on backwards. Ensure you correct the issue so that the arrow is in the correct orientation before riding.

When you are ready for a new set of tires, take your ElliptiGO bike to a professional bike mechanic and have them install your tires with the same size of high pressure clincher tire.



Tubes

Your ElliptiGO® bike comes with high-pressure tubes. There are two kinds of valves used on inner tubes in the bike industry. Schrader valves are frequently used for low-pressure tubes and are the same valves you'll find on automobile tires. Presta valves are frequently used with high-pressure tubes. Each valve type requires a different pump head for inflation. Your ElliptiGO bike comes equipped with high pressure tubes that use a Presta valve. To inflate them, you can use a pump head configured for use with a Presta valve, or you can use a Presta-valve adapter with a pump head configured for Schrader valves.

To inflate your tubes, follow these steps:

1. Gently loosen the locking nut at the top of the Presta valve by turning it counterclockwise several turns until it reaches the end of the center thread. DO NOT remove the locking nut - stop turning it once it reaches the end of the center thread.
2. Push down briefly on the nut to ensure that the Presta valve is not stuck in the locked position. A small amount of air should escape.
3. If you are using a pump head configured for a Presta valve, proceed to the next step. If you are using a pump head configured for a Schrader valve, screw the larger end of your Presta-valve adapter onto the metal valve stem.
4. Place the pump head over the valve.
5. Inflate to the proper pressure. We recommend inflating your tires 5% - 10% under the max pressure printed on the tire sidewall. The rims on your bike are designed to accept 20" X 1.5" - 1.75" tubes with Presta valves, so whenever you purchase a spare tube, ensure that it is this size and has a Presta valve.



Chain Keeper on the Arc Model

The ElliptiGO Arc comes equipped with a chain keeper located to the inside of the chainring. The purpose of the chain keeper is to reduce the likelihood that your chain will become detached from the chainring while riding. While it is impossible to ensure that a chain will never detach from the chainring, a properly adjusted chain keeper should prevent most potential chain detachments from taking place. The chain keeper is properly adjusted when there is between 1 and 2 mm of space between the lowest face of the chain keeper and the inside edge of the chainring.

Adjusting the Chain Keeper

To adjust the chain keeper, follow these steps:

1. If the chain keeper is contacting the chain or chainring, cycle the drivetrain by hand to identify the point in the stroke where the chain keeper contacts the chain or chainring. Once you have located the point where contact is being made, keep the cranks in that position for the remainder of these steps.
2. Insert a 4mm Allen wrench into the chain keeper fixing bolt and turn it counter-clockwise to loosen the bolt.
3. Move the chain keeper away from the chainring until there is a gap of at least 1mm but no more than 2mm between the inside edge of the lowest face of the chain keeper and the inside edge of the chainring.
4. Using the 4mm Allen wrench, tighten the fixing bolt to 6-8 Nm.
5. Re-check the gap between the lowest face of the chain keeper and the chainring to ensure it is between 1 and 2mm wide.

⚠️WARNING! A properly adjusted chain keeper is a critical safety feature. It is your responsibility to ensure that it remains set at the appropriate distance from the chainring. Failure to do so could result in a chain detaching from the sprocket unexpectedly during a ride. This could cause you to lose control of the bike and suffer a fall.



CHAPTER 3: Riding

Basic Cycling Safety

Before riding your ElliptiGO elliptical cycle, you should become familiar with the basics of cycling safety. The following includes many of the fundamental aspects of cycling safety; however, it is not an exhaustive list.

For a more thorough education on cycling safety we recommend that you contact a certified bicycling instructor and enroll in a bicycle safety course. Here are the basic principles you should adhere to:

Wear a Helmet, Protective Equipment and Appropriate Clothing

Always wear a Department of Transportation (DOT) approved helmet when riding your ElliptiGO bike. Make sure to follow the helmet

manufacturer's instructions regarding proper fitting and how to maintain your helmet so it can provide the most protection for your head during a fall.

▲WARNING! When riding the ElliptiGO bike, your head will be much higher off the ground than it would be on a regular bicycle and you could suffer even more damage to your head as a result of a collision or fall than you might if you fell off a conventional bicycle. As a result, wearing a helmet is even more critical when riding the ElliptiGO bike. Failure to do so could result in serious injury or death.

In addition to an approved helmet, we recommend that you wear closed-toed running or walking shoes

with short shoelaces tied in a double knot, cycling gloves, protective glasses with plastic shatterproof lenses, and brightly colored clothing.

Before riding, always check your clothing to make sure there is nothing dangling that could become caught in the moving mechanisms of the ElliptiGO bike. Pay particular attention to shoelaces, wide-bottomed pants, and long dresses as these could get caught in the drive train mechanism, around the rear wheel, or in the drive tracks. If something dangling from your body gets caught in any of these locations, it will likely cause you to lose control of the ElliptiGO bike and fall, resulting in serious injury or death.

Ensure that you have any other required safety equipment mandated by your state or municipality. It is your responsibility to comply with the law where you are riding.

Select a Safe Route and Riding Conditions

Choose a cycling route and time of travel that avoids high traffic areas and dangerous streets. Choose routes that have few cars, well maintained streets, and wide bike lanes. If possible, always ride during good conditions and never at night or in inclement weather.

⚠️ WARNING! Riding at night or during inclement weather significantly increases your chances of suffering a collision or fall that causes significant injury or death.

⚠️ WARNING! Wet weather adversely impacts visibility, traction, braking and maneuvering for the ElliptiGO bike rider as well as other cyclists and motorists. Emergency stopping distances increase significantly. Always ride more slowly in wet conditions and begin slowing down far earlier than would be necessary under dry conditions. Never take sharp corners at high speed or attempt to corner while braking in wet conditions.

⚠️ WARNING! Riding during periods of low visibility, such as nighttime and in areas of dense fog, drastically increases your chances of being struck by a motorist or other cyclist and suffering significant injuries or death. You should refrain from riding the ElliptiGO bike during these periods.

⚠️ WARNING! Do not rely on reflectors to provide adequate lighting during periods of low visibility, especially dense fog. Reflectors cannot substitute for appropriate lights. **DO NOT REMOVE THE INSTALLED REFLECTORS FROM YOUR BIKE.** Removing them can lower the chances you will be seen during periods of low visibility, reducing your level of safety. Inspect your reflectors often to ensure that they are clean, straight, and undamaged. Have your reflectors repaired or replaced if they are damaged or misaligned.

If you choose to ride during periods of low visibility, you should take many precautions, including:

1. Wearing very bright clothing with integrated reflective materials and several other highly-visible items such as an approved bicycle safety vest, lights on your body, helmet and ElliptiGO bike, and reflective stickers or straps on your helmet and clothing. Ensure that these reflective surfaces are free from obstruction by objects you are carrying and your other clothing.
2. Using head and tail lights (either battery or generator powered) that are bright enough to enhance your ability to see and be seen and meet all legal requirements for your jurisdiction.
3. Riding slowly and through well-lit areas with less traffic and designated bike lanes or paths. When riding, choose a manner and path that maximizes the chances that a motorist, cyclist or pedestrian will see you while minimizing the chances that you will collide with them. Also, ride at a speed that affords plenty of time to react to, and avoid, unexpected obstacles.
4. Never making aggressive or unpredictable maneuvers that could catch a motorist or cyclist off guard.

Understand and Obey the Law

In most jurisdictions, cyclists are subject to the same traffic laws as motorists. Always stop at stop signs and red lights and use correct hand signals.

Many jurisdictions have additional laws and regulations that only pertain to cyclists. In particular, observe regulations about bicycle paths, trails and routes, use of a bicycle on a sidewalk, proper front and rear lighting, helmets, seating, signaling, reflectors, licenses and any special bicycle traffic laws in your jurisdiction. As with every other aspect of the administrative state, it is your responsibility to know the law and obey it. Our failure to provide you with a component or specific safety device required by the law in your jurisdiction does not relieve you of the requirement to install that component or safety device on your ElliptiGO® bike.

Ride Defensively

Even though you can see other motorists, cyclists and pedestrians, always assume that they cannot or do not see you and take precautions accordingly. Anticipate obstacles and dangerous conditions by looking ahead and paying attention to the environment around you. Always be ready to avoid vehicles entering the bike lane, children and animals darting into the roadway, poor road conditions (including potholes, rocks, sharp edges at the road shoulder, and loose gravel), separations in the asphalt or concrete, grates, glass and other sharp objects, pedestrians and the unexpected opening of parked car doors.

Ride at a controlled speed, especially when descending hills or in adverse weather conditions. The higher the speed, the less time you will have to react to dangerous conditions, so always choose a speed that is appropriate for your environment.

Use extreme caution when overtaking other cyclists, approaching blind intersections, and when merging with vehicular traffic. Slow down and look both ways whenever crossing an intersection.

Share the Road – stay to the side of the road and avoid interfering with the progress of motorists and faster cyclists.

Maintain a sharp focus on your surroundings. Never wear headphones, talk on a cell phone, or become distracted by electronic devices such as odometers, heart rate monitors, watches, and the like. These distractions can delay your reactions to developing dangerous conditions and increase your risk of suffering serious injury or death.

Avoid weaving through traffic and making unexpected maneuvers, especially when in the presence of cars or other cyclists.

Never hold onto another moving vehicle, including
ELLIPTIGO Owner's Manual

another cyclist, when riding your elliptical bike. This behavior can be extremely dangerous and result in the rider losing control of the bike and suffering a fall.

Never ride an ElliptiGO® product while under the influence of alcohol or any other substance that impairs judgment, cognition, motor function or balance. This increases the risks of colliding with another object or losing control of the bike and suffering a fall, either of which could cause serious injury or death.

Never carry anything that could impede your vision or adversely impact your ability to control the elliptical bike.

Take Responsibility for Your Safety

As discussed above, you are responsible for the safe handling and maneuvering of your ElliptiGO bike. Make sure to follow the instructions in this owner's manual. Get to know the mechanical workings of your bike and always do a pre-ride safety check to ensure everything is in good working order. Make sure that all quick releases and safety mechanisms are properly engaged. Pay particular attention to the condition of your tires, brakes and load wheels as a failure by one of these components would be particularly dangerous. Double check the security of the steering column, ensure that it is not above the "Max Extension" line, and that the safety mechanisms are properly engaged.

Always wear a DOT approved cycling helmet that meets

the latest certification standards and is appropriate for road cycling. Always follow the helmet manufacturer's instructions for fit, use and care of your helmet. Many serious bicycle-related injuries include head injuries which might have been avoided if the rider had worn an appropriate helmet. Before riding your ElliptiGO, consult with your physician so he or she can determine if you are healthy enough to do so.

⚠️ WARNING! Riding without an approved helmet greatly increases your chances of suffering serious injury or death during a crash or fall.

⚠️ WARNING! Riding with damaged, poorly maintained or improperly engaged components can result in an unexpected failure of a critical element of the ElliptiGO bike. The failure of a critical element of the bike is likely to result in the rider falling and suffering a serious injury or death.



Adjusting the Fit

Before riding your ElliptiGO, it is important that it is set up to fit you correctly. Your ElliptiGO bike has several adjustable features that you should use to ensure you are getting the most comfortable and safest riding experience possible.

All ElliptiGO models enable you to adjust the steering height and position of the controls. On the 3C, 8C, 8S and 11R models, the foot platforms are oversized so that you can move your foot into different positions while riding and the length of the stride is adjustable from 25" down to 16". On the Arc model, the location of the foot platform itself can be modified and the height of the stride is adjustable from 12" to 9".

Adjusting the Steering Height

The correct steering height is really a matter of preference and will vary for every rider. We recommend setting the height of the handlebars where they enable you to ride in a comfortable, upright position with your torso directly above your legs and with little to no weight on your hands or wrists. Although everyone's proportions are different, this usually means that taller people ride with a higher steering height and shorter people use a lower steering height. To adjust the steering height, follow the detailed instructions set forth in the Steering Columns section above.

Adjusting the Controls

Rotating the handlebars moves the controls either away from or closer to the rider. While most people find the

factory setting to be comfortable, a few require this adjustment for the most comfortable and safest riding experience. However, after adjusting the handlebars, the grips, shifter, and brake levers will all require re-positioning. Riding with the controls in the wrong position can be extremely unsafe, so it is critical that these controls are positioned correctly. As a result, this adjustment should only be done by a professional bicycle mechanic or certified ElliptiGO technician.

⚠️WARNING! Rotating the handlebars could re-position the controls such that your bike is unsafe to ride. Always have a professional bike mechanic position the controls so that they can be used safely while riding.

Another adjustable feature on the controls is the brake reach, which is the distance from the handlebar grip to the brake lever. This distance can be adjusted to accommodate a wide range of hand and finger sizes. Because of the technical nature of this adjustment and the importance of having it done properly, this adjustment should only be done by a professional bicycle mechanic or certified ElliptiGO technician.

⚠️WARNING! Because the braking force is created by pulling on the brake levers, have the reach set up correctly is critical for safe riding. Moreover, the shorter the reach is set, the more important to ensure that the brake levers are adjusted correctly. If the brake levers do not have enough space to fully actuate the brakes, you will not be able to employ full braking power. This will likely increase your stopping distance and make it more likely that you will be unable to avoid a dangerous

obstacle or condition on the road, potentially resulting in serious injury or death. If you choose to have your brake reach adjusted, ensure the adjustment is done by a professional bicycle mechanic or certified ElliptiGO technician.

Adjusting the Stride Length on C-Series, 8S and 11R Models

The crank arms on the C-series and models 8S and 11R provide four different mounting positions for the drive arms. Each mounting position generates a different stride length according to the following table:

Mounting Position	Stride Length [in.]
One	16
Two	19
Three	22
Four	25

Your ElliptiGO comes from the factory with the stride length set in the longest position. It is the preferred position for most people. Unless you are shorter than 5'2" in height or your legs have a limited range of motion, we recommend trying the bike in the longest stride length first to see how that feels. If you are shorter than 5'2", your legs have a limited range of motion or the longest stride length position feels too long for you, then we recommend moving down one position at a time until you find the one that feels best for you.

To adjust the stride length, follow these steps:

1. Place the bike on the kickstand.
2. Some bikes come equipped with a retention screw on the inside of the crank arm. If your bike does not have a retention screw (Photo 2a), then proceed to step 4. If your bike does have a retention screw (Photo 2b), then proceed to the next step.

NOTE: If your bike has a silver drive arm axle, it should be equipped with a drive arm axle retention screw. If you believe you are missing a drive arm retention screw, contact service@elliptigo.com for assistance.



3. Looking at the bike from the left side, insert a 2.5mm Allen wrench into the drive arm axle retention screw on the right crank arm. Rotate the Allen wrench clockwise until the screw is completely removed.
4. Insert a 6mm Allen wrench into the back of the right drive arm axle. While holding the drive arm still, rotate the Allen wrench clockwise until the drive arm axle is completely unscrewed.
5. Remove the washer from the crank arm counter-bore and insert it into the counter-bore of the new position.



6. Using your fingers, thread the drive arm axle counter-clockwise several rotations into the new mounting position on the right crank arm, ensuring that the threads are aligned correctly and not binding. Once the drive arm axle is threaded into the new position several turns, insert a 6mm Allen wrench into the drive arm axle and, while ensuring that the washer remains flat in the counter-bore, rotate the wrench counter-clockwise until the axle is fully seated. Torque the axle to 34 N-m.
7. If your bike does not have a drive arm retention screw, proceed to the next step. If your bike has a drive arm retention screw, insert it into the back of the drive arm axle. Using a 2.5mm Allen wrench, rotate the retention screw counter-clockwise until it is seated flush against the drive arm axle.
8. Repeat steps 2-6 for the left drive arm. NOTE: To loosen the left drive arm axle retention screw (if any) and drive arm axle, stand on the right hand side of the bike and turn your wrench counter-clockwise. To tighten, turn them clockwise.



Foot Platform Anatomy for Arc Models



Adjusting the Stride Height on the Arc Model

The foot platform assembly on the Arc model has two adjustments. The platform can be adjusted relative to the pivot axle and the pivot axle can be adjusted relative to the drive arm. Not all combinations of foot platform and pivot axle positions are compatible. For a list of what combinations will work, see the Platform Positioning Chart below

⚠️ WARNING! After making any adjustment to the foot platform or pivot axle, always ensure that the new settings fall in an “OK” position on the Foot Platform Positioning Chart below. If the new combination falls in a red area, then **DO NOT RIDE**. Reset your positions such to place them in an OK area on the chart. Riding with positions falling in a red area will likely result in the foot platform striking the swing arm or frame during riding, which could cause the rider to lose control and suffer a fall.

The stride height for the Arc model is determined by the location of the pivot axle on the drive arm. Moving the pivot axle rearward on the drive arm increases the height component of the elliptical stride. Conversely, moving the pivot axle forward on the drive arm decreases the height component of the elliptical stride. Typically, taller riders will prefer more stride height and shorter riders will prefer less.

To adjust the pivot axle location, follow these steps:

1. Using a 4mm Allen wrench, loosen the four platform base bolts.
2. Slide the pivot bracket along the drive arm until you reach the desired location.
3. Tighten the platform base bolts a little at a time until the bracket is seated evenly against the drive arm, then tighten each bolt to 6-8 Nm.

Again, once you have set the new pivot axle location, check the Foot Platform Positioning Chart on the next page to ensure that your bike is safe to ride.

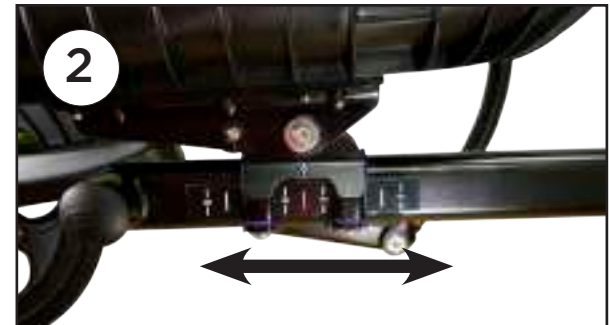

FOOT PLATFORM POSITIONING ON ARC

The ElliptiGO Arc foot platforms and pivot axle locations are originally set at 2.5 and 2.5. Many combinations of foot platform location and pivot axle location are not compatible. If you choose to adjust one or both of these settings, ensure that the new settings fall in an “OK” position on the chart below. If the new combination falls in a position that states “DO NOT RIDE”, then reset your positions so that they fall in an “OK” area of the chart. **Riding in a DO NOT RIDE position will likely result in the foot platform striking the swing arm or frame during riding, which could cause the rider to lose control and suffer a fall.**

		Foot Platform Position												
		Smaller Shoe Size					Larger Shoe Size							
Pivot Axle Position Determines the Stride Height	Rider Height	Setting	1	1.5	2	2.5	3	3.5	4	4.5	5	5.5	6	
	Shorter Riders (less vertical)	1	OK	OK	DO NOT RIDE	DO NOT RIDE	DO NOT RIDE	DO NOT RIDE	DO NOT RIDE	DO NOT RIDE	DO NOT RIDE	DO NOT RIDE	DO NOT RIDE	DO NOT RIDE
		1.5	OK	OK	OK	DO NOT RIDE	DO NOT RIDE	DO NOT RIDE	DO NOT RIDE	DO NOT RIDE	DO NOT RIDE	DO NOT RIDE	DO NOT RIDE	DO NOT RIDE
		2	OK	OK	OK	OK	DO NOT RIDE	DO NOT RIDE	DO NOT RIDE	DO NOT RIDE	DO NOT RIDE	DO NOT RIDE	DO NOT RIDE	DO NOT RIDE
		2.5	OK	OK	OK	DEFAULT	OK	DO NOT RIDE	DO NOT RIDE	DO NOT RIDE	DO NOT RIDE	DO NOT RIDE	DO NOT RIDE	DO NOT RIDE
		3	OK	OK	OK	OK	OK	OK	DO NOT RIDE	DO NOT RIDE	DO NOT RIDE	DO NOT RIDE	DO NOT RIDE	DO NOT RIDE
		3.5	OK	OK	OK	OK	OK	OK	OK	OK	DO NOT RIDE	DO NOT RIDE	DO NOT RIDE	DO NOT RIDE
	Taller Riders (more vertical)	4	OK	OK	OK	OK	OK	OK	OK	OK	OK	DO NOT RIDE	DO NOT RIDE	DO NOT RIDE
		4.5	OK	OK	OK	OK	OK	OK	OK	OK	OK	OK	DO NOT RIDE	DO NOT RIDE
		5	DO NOT RIDE	OK	OK	OK	OK	OK	OK	OK	OK	OK	OK	OK
		5.5	DO NOT RIDE	DO NOT RIDE	OK	OK	OK	OK	OK	OK	OK	OK	OK	OK
6		DO NOT RIDE	DO NOT RIDE	DO NOT RIDE	OK	OK	OK	OK	OK	OK	OK	OK	OK	

Adjusting the Foot Platform Position on the Arc Model

On the Arc model, the foot platform can be adjusted relative to the pivot axis to improve the functioning of the pivot while pedaling. Each foot platform is secured to the pivot by four screws and is labeled with position indicators. Typically, the larger the rider's foot, the further forward the platform will need to be for optimal pivoting and the smaller the rider's foot, the further back the platform will need to be for optimal pivoting. The foot platform positions are numbered from 1-6 with 1 being the furthest back position and 6 being the furthest forward position. Once you have set the new foot platform location, check the Foot Platform Positioning Chart on the next page to ensure that your bike is safe to ride.

To adjust the foot platform position, follow these steps:

1. Using a 4mm Allen wrench, loosen the foot platform screws until they clear the teeth in the foot platform screw channels.
2. Slide the foot platform to the desired position and ensure that the screws and washers are aligned between the foot platform channel teeth.
3. Tighten the screws to 4-6 Nm.

⚠️ WARNING! After making any adjustment to the foot platform or pivot axle location, always ensure that the new settings fall in an "OK" position on the Foot Platform Positioning Chart above. If the new combination falls in a red area, then **DO NOT RIDE**. Reset your positions such to place them in an OK area on the chart. Riding with positions falling in a red area will likely result in the foot platform striking the swing arm or frame during riding, which could cause the rider to lose control and suffer a fall.



Pre-Ride Safety Checklist

Before riding, always visually and physically inspect the ElliptiGO® elliptical cycle to ensure that it is in good riding condition. With the bike supported on its kickstand, you should inspect the bike using the following checklist prior to each ride:

1. Thoroughly examine the front and rear tires on both sides for signs of damage (this will require you to spin the tire periodically to observe the part that was contacting the ground). Use a tire gauge to ensure that each tire is inflated to the proper pressure annotated on the tire's sidewall. Adjust the tire pressure if necessary.
2. Inspect the front wheel quick release system to make sure that the hub is securely seated on the fork and that the quick release has been closed properly with the appropriate amount of force. The mechanism should emboss the fork-ends when closed to the locked position. See the section on the Quick Release Clamping Systems for details on how to ensure the quick release is securely fastened.

⚠️WARNING! An improperly secured quick release lever on the front wheel can allow the wheel to disengage from the fork. This condition is exceptionally hazardous and will cause the rider to suffer a fall that will almost certainly result in serious injury or death. BEFORE RIDING ALWAYS ENSURE THE FRONT WHEEL QUICK RELEASE IS PROPERLY SECURED.

3. With the kickstand retracted, raise the front end of the bike off of the ground several inches and then drop it. Watch and listen for unusual movements or noises as the bike strikes the ground. If you hear an unusual noise, continue this test until you can locate the problem. Do not ride the ElliptiGO bike until the problem is resolved. When in doubt, take the bike to a professional bicycle mechanic for service or contact our service department at service@elliptigo.com.
4. Inspect the wheels to ensure that they are true. Spin each wheel and watch it as it rotates to make sure it spins straight, without any side-to-side wobble. Also, make sure that the wheel does not rub intermittently against one or both brake pads. Any side to side wobble or intermittent rubbing indicates that the wheel is out of true.

⚠️WARNING! A wheel that is not true can present a very dangerous situation because it interferes with the proper functioning of the brakes. It requires expertise and proper tools to correctly true a wheel. Always have a professional bicycle mechanic true your wheels. Riding on a wheel that is not true could cause you to lose control and suffer a fall.

5. Make sure that the rims are not damaged or worn out, that the tops of the rims are securely engaging the tire at the rim bead, and that the rim braking surfaces are clean and free from damage. Feel the rim on both sides to make sure the wear indicator is still present and that there is no bowing, indentations, or other damage to the rims. They should be flat and smooth with a pronounced wear indicator groove.

⚠️WARNING! Riding on damaged rims, worn out rims or rims that do not secure the tire is extremely dangerous. Rims in these conditions can catastrophically fail without notice, causing the rider to fall and be seriously injured or killed. CHECK YOUR RIMS BEFORE RIDING!

6. Inspect the spokes on the front and rear wheels to ensure that none are missing, that they are all tight, and that they are all properly aligned.

7. Inspect the front and rear brake pads to ensure they are in good condition and securely attached.

8. Actuate the front and rear brake levers while watching the brakes to make sure that both are functioning properly and that each pad contacts the wheel rim in the correct position. Check that the brake noodle is seated into the brake quick release system and the brake cable is seated into the top end of the noodle and is free from pinches or sharp turns. Ensure that the brake pads contact the rim within the first inch of pulling on the levers and each brake pad lands completely on the rim.

No brake pad should contact the tire or overhang off of the rim and you should be able to apply full braking power before the levers contact the handlebars.

If your brakes are not working properly, do not ride the ElliptiGO® cycle. Instead, take your bike to a professional bicycle mechanic to have the brakes adjusted.

⚠️WARNING! Improper brake alignment and functioning can result in the rider losing control of the elliptical bike and suffering a fall, which can result in significant injury or death. Always make sure your brakes are working properly before riding.

9. Thoroughly inspect the steering column to ensure that it is secure, all components are properly aligned, and the quick release levers are securely fastened. If the steering column includes a safety pin, ensure that it is fully-seated into the proper corresponding hole. Check that the handlebars are aligned properly with the front wheel. See Adjustable Steering Height for details on how to properly adjust steering column components. See Quick Release Clamping Systems for details on how to ensure the quick release is securely fastened.

▲ WARNING! Failure to properly secure the steering column could result in the unexpected collapsing of the steering column during riding. This would likely cause the rider to lose control and suffer serious injury or death from a resulting fall.

10. Test the grips and bar ends (if any) on the handlebars. They should be in good condition and securely fastened so that they cannot be rotated. Improperly secured grips and/or bar ends can detach from the handlebars during riding and cause the rider to lose control and fall.

11. Ensure that each end of the handlebar is capped with a smooth surface. A handlebar end can have sharp edges that, if exposed, can cut a rider or exacerbate injuries sustained during a fall.

12. For C-series and model 8S and 11R bikes, actuate the gear shifter, shifting up and down to ensure the gear shifter is shifting smoothly in both directions. For the ELLIPTIGO® Arc, shifting without pedaling is not possible so do not perform this step.

13. For C-Series and model 8S and 11R bikes, inspect the guide track systems. Inspect each load wheel to ensure that there are no cracks or chips and it operates properly. Spin each one individually so you can see and feel the entire circumference of the wheel. Check each guide track to make sure that it is free from debris.

▲ WARNING! A cracked load wheel can come apart while riding, causing the drive arm to get jammed and resulting in a fall. IF YOU FIND A CRACK IN YOUR LOAD WHEEL DO NOT RIDE YOUR ELLIPTIGO UNTIL THE LOAD WHEEL HAS BEEN REPLACED. Contact service@elliptigo.com for replacement load wheels and instructions for how to replace them.

14. Ensure that drive train is functioning properly by using your hand to grab the outside edge of the closest foot platform and then rotate it backwards several complete rotations.

▲ CAUTION! NEVER GRAB THE REAR OF THE DRIVE ARM as your hand can get caught between the drive arm and the cranks and suffer an injury

15. Visually inspect each drive arm and swing arm (if any) carefully to ensure each has no visible signs of damage, especially cracking. Make sure you inspect all sides of each arm. If a drive arm or swing arm has visible signs of damage or cracking, DO NOT RIDE the bike. Instead, contact our service department at service@elliptigo.com for support.

▲ WARNING! Some ELLIPTIGO bikes are equipped with drive arms made from a composite material commonly known as carbon fiber. Although it is a strong and light material, when it fails, it tends to fail catastrophically and with little or no warning. As a result, it is extremely important to inspect the drive arms thoroughly before riding to ensure that there are no signs of cracking. If you

spot damage on a composite drive arm, DO NOT RIDE the bike. Instead, contact our service department at service@elliptigo.com for support.

16. Visually inspect the frame to ensure it is free from damage.

17. For C-series and model 8S and 11R bikes, check the adjustment on the internal hub. *Shimano 11-speed:* Make sure that the gear shifter is in 6th gear and then look into the alignment window. Ensure that the yellow indicators are aligned. *Shimano 8-speed:* Make sure that the gear shifter is in 4th gear and then look into the alignment window. Ensure that the yellow indicators are aligned. *Sturmey-Archer 3-speed:* Make sure that the gear shifter is in 2nd gear and ensure that the tip of yellow arrow is between the two yellow marks. If the yellow indicators or arrow are not aligned, visit our website support page for a how-to video or refer to the Gearing Systems section for more information.

⚠WARNING! NEVER RIDE ON AN INCORRECTLY ADJUSTED HUB. If your hub is not properly adjusted, it can malfunction during normal riding. For example, it can unexpectedly come out of gear, fail to shift, or shift unexpectedly. Any of these situations can cause the rider to lose control and suffer a fall.

18. Ensure that the chain has the appropriate amount of tension and is clean and lubricated. For C-series and models 8S and 11R, when rotating the chain, you should feel “tight spots” and “loose

spots” because the large and small cogs are not perfectly round. The chain has the appropriate amount of tension for these bikes when it is tight without binding thru the entire revolution of the crank arm. ElliptiGO Arc bikes come equipped with a chain tensioner. Check to see that the chain tensioner is performing correctly.

19. For C-series and models 8S and 11R, check that the nuts holding the rear wheel to the frame are tightened appropriately. For torque specifications refer to The Torque Requirements for Screws and Fasteners section below. For the ElliptiGO® Arc, check that the rear wheel is properly seated in the frame dropouts and that the quick release lever is properly secured.

⚠WARNING! Loose rear wheel nuts or an improperly secured quick release lever on the rear wheel can allow the rear wheel to come loose while riding. This condition is exceptionally hazardous and can cause the rider to suffer a fall that will almost certainly result in serious injury or death. BEFORE RIDING ALWAYS ENSURE THE REAR WHEEL IS PROPERLY SECURED.

20. If you have mounted toe cages on your drive arm foot platform, ensure that they are properly adjusted for the shoes you are wearing.

21. For the Arc model, check the foot platform security and adjustment. Check that each foot platform is adjusted correctly relative to the pivot axle below and is securely fastened to the pivot axle. Then check that

the pivot axle is functioning properly, is located in the correct spot on the drive arm and is securely fastened to the drive arm.

22. Ensure that you have a set of spare parts including at least one replacement tube, tools, and pump and they are securely and safely fastened to you or your bike.

23. Finally, do a thorough once over of the entire machine, including checking each screw, bolt, fastener, and quick release system to make sure nothing is loose, damaged or appears like it will not function properly. To make sure that the many fasteners on your elliptical cycle are correctly tightened, refer to the section on Torque Requirements for Screws and Fasteners below.

▲WARNING! It is very important that your screws, fasteners and quick release levers are properly tightened. Not applying enough force increases the chance that they will become loose and fail to perform their function properly, increasing the risk of a failure. Over tightening them can damage the fastener, elevating the risk of a failure. The failure of a fastener or improper tensioning on a quick release may lead to a component failure that causes the rider to lose control and suffer a fall. Ensuring that your screws and fasteners are tightened correctly requires the skillful use of a torque wrench and we strongly recommend having a professional bicycle mechanic tighten them. If you would prefer to tighten the screws and fasteners yourself, you must use a calibrated torque wrench and ensure you reach the correct torque as specified the section on Torque Requirements for Screws and Fasteners below.

From time to time, it is possible that you will need to adjust screws or fasteners during a ride. In these rare situations, you must exercise the utmost of care and we recommend having a professional bike mechanic check the fasteners you adjusted as soon as you can.

Familiarization Ride

Before heading out into traffic on a “real ride,” you should become familiar with riding your elliptical bike in a controlled environment until you can handle the bike well enough to ride safely in an uncontrolled environment. If you have not already adjusted the bike to fit you correctly, follow the instructions in the Adjusting the Fit section above. Once your elliptical cycle is properly adjusted, follow these instructions to familiarize yourself with how it functions.

Find a Good Location

Bring the machine to a controlled, dry, paved location free of obstacles and traffic that is large enough to maneuver safely. A closed-off or empty parking lot that is at least 100 yards by 40 yards (about the size of a football field) could be a good spot.

Put on Your Helmet, Appropriate Clothing, and Protective Gear

Every year thousands of cyclists suffer head and neck injuries as a result of collisions or falls. Some of these head injuries could have been reduced in severity or avoided entirely if the rider were wearing a Department of Transportation approved helmet properly at the time of the fall or collision. Every helmet is different and each helmet comes with a set of instructions addressing how to properly fit and adjust the helmet, as well as how to care for it. Follow these instructions to properly adjust your helmet before you begin riding your ElliptiGO® bike.

⚠️WARNING! When riding an elliptical cycle, your head will be much higher off the ground than it would be on a regular bicycle. As a result, you could suffer even more damage to your head as a result of a collision or fall than you might if you were riding a conventional bicycle. Do not become another statistic; always wear a properly fitting helmet when riding your bike. Failure to do so could result in significant injury or death.

In addition, make sure that you are wearing brightly colored and well-fitting clothes, eye protection, and closed-toe shoes. Check to make sure nothing is dangling from your body or is so loose that it could contact any of the machine’s moving parts. In particular, make sure that your shoestrings are not too long to get caught in the moving mechanisms, especially the rear wheel, chain, sprockets, and drive arms. Never ride an elliptical cycle in open-toed shoes, flip flops, sandals or barefoot.

Inspect the ElliptiGO Bike and Get Familiar with the Brakes and Gear Selector Levers

Execute the pre-ride inspection according to the checklist above. Then, with the ElliptiGO situated securely on the kickstand, practice squeezing the brakes. Ensure that they have the correct brake reach and are functioning properly.



Start Your First Practice Ride

Once you are familiar with operating the brakes, have your helmet on, and have the appropriate clothes and other safety gear. To get started, place the gear selector lever into the 5th position for the Arc, 8C, 8S and 11R models, and the 1st position for the 3C model. Move the bike off of the kickstand. Place one foot on the ground and the other one squarely onto the flat portion of the corresponding foot platform. Generate forward momentum by pushing off the ground with your ground-based foot and then stand up onto your platform-based foot, balancing the bike as you roll forward. Once you have your balance, place your ground-based foot onto the foot platform on the other drive arm. Begin to take slow strides as in walking to propel the elliptical cycle forward and then gradually increase your cadence as you get comfortable.

Be very mindful of your height when riding. Your head will be 12-18 inches higher than your standing height, and there are many low-hanging objects like tree branches, signs, underpasses, and the like that could strike you on your ride if you are not paying attention.

⚠️WARNING! During mounting and riding always ensure that each foot is resting squarely on the flat portion of the foot platform. If your foot is not placed correctly on the foot platform, it can slip off the platform, contact the frame, or get caught in the bike's moving parts, any of which could cause you to lose control and suffer a fall.

⚠️WARNING! YOUR HEAD IS VERY HIGH OFF THE GROUND WHEN RIDING AND COULD HIT STATIONARY OBJECTS. Always look out for objects like tree branches, signs, underpasses, etc. that are usually higher than pedestrians or cycling traffic, but may be low enough to strike you on your ElliptiGO bike. Hitting an object with your head while riding will likely cause you to lose control and fall, resulting in serious injury or death.

Test the Brakes

Your ElliptiGO cycle comes equipped with front and rear rim brakes actuated by levers attached to the handlebars. One brake lever operates the front brake and the other operates the rear brake. To test the brakes, start riding the bike slowly and stop pedaling. Prepare to stop by standing upright in a balanced position. Gently apply braking pressure to the rear brake first, then to the front brake. Always apply the brakes in a smooth controlled manner until you come to a complete stop. As you approach a complete stop, make sure to place your foot on the ground so you don't fall over.

⚠️WARNING! Always apply the brakes in a smooth controlled manner. Start braking with the rear brake first, but always use both brakes to control speed. Applying the brakes too quickly or with too much force can result in a wheel "locking up" and the rider losing control and suffering a fall.

Some ElliptiGO® bikes come equipped with bar extensions at the end of each handlebar. Although

these extensions can be helpful for climbing hills, they position your hands further away from the brakes and shifters than when properly positioned on the grips. NEVER ATTEMPT TO BRAKE WITHOUT HAVING BOTH HANDS SECURELY POSITIONED ON THE HAND GRIPS. Braking with only one hand securely positioned on the hand grips and the other on the bar extensions can cause the rider to lose control of the bike and suffer a fall.

⚠️ WARNING! Always ensure both hands are securely positioned on the hand grips before braking. Braking with only one hand on the hand grips can cause the rider to lose control and suffer a fall.

Get Familiar with Turning, Starting and Stopping

Ride your elliptical bike for at least 20 minutes in this safe environment, ensuring that you make several starts and stops and right and left turns. Practice shifting through the gears and getting a feel for what gear is appropriate for you at different speeds. If something doesn't feel right or something happens that makes you unsure about any aspect of your machine or the riding experience, stop riding and contact ElliptiGO customer service at service@elliptigo.com to resolve the issue before attempting a subsequent ride.



Riding Techniques

Before any ride, we highly recommend executing the Pre-Ride Checklist. **Do not ride an elliptical cycle without a helmet and proper clothing, including closed-toe shoes, ensuring that all of the components are working properly and all screws, fasteners and quick release levers are properly closed.**

Your ElliptiGO® product is an advanced piece of fitness equipment. It is designed to be used on paved surfaces for exercise. It is not a toy, nor is it designed to be used on trails, dirt, sand, gravel, or other rough surfaces. Moreover, it is never to be used for trick or stunt riding, or to be ridden off of jumps, curbs, ditches, drops or other extreme obstacles.

ALERT! Using your ElliptiGO product improperly could seriously damage it and void your warranty.

⚠️ WARNING! ElliptiGO products are designed exclusively for on-road use to get exercise. Riding on rough road surfaces or doing trick or stunt riding could cause one or more components to fail, which will likely result in a fall that could cause serious injury or death. **ONLY USE YOUR ELLIPTICAL BIKE ON PAVED SURFACES AND DO NOT ENGAGE IN TRICK OR STUNT RIDING.**

⚠️ WARNING! YOUR HEAD IS VERY HIGH OFF THE GROUND WHEN RIDING AND COULD HIT STATIONARY OBJECTS. Always be looking out for objects like tree branches, signs, underpasses, etc. that are usually higher than pedestrians or cycling traffic, but may be low enough

to strike you on your elliptical bike. Hitting an object with your head while riding will likely cause you to lose control and fall, resulting in serious injury or death.

As a rule, you should always have two hands on the handlebars unless you are signaling. Unlike a conventional bicycle, elliptical cycles cannot be ridden “with no hands.” Similarly, you should only use the bar extensions (if present) when climbing hills, and never in traffic or other situations that could require emergency maneuvers. NEVER ATTEMPT TO BRAKE WITHOUT HAVING BOTH HANDS SECURELY POSITIONED ON THE HAND GRIPS. Braking with only one hand securely positioned on the hand grips and the other on the bar extensions can cause the rider to lose control of an elliptical bike and suffer a fall.

⚠️ WARNING! Always ensure both hands are securely positioned on the hand grips before braking. Braking with only one hand on the hand grips can cause the rider to lose control and suffer a fall.

Also, be very mindful of your height when riding. Your head will be 12-18 inches higher than your standing height, and there are many low-hanging objects like tree branches, signs, underpasses, and the like that could strike you on your ride if you are not paying attention.

Climbing and Descending Hills

Be cautious when climbing and descending hills. Prior to reaching a hill to climb, prepare to shift into a lower gear. The steepness of the hill will determine which gear is the correct one to select. Once you have reached the hill, shift into the correct gear and apply power using the same riding technique that you use on level ground. If the hill is steep, lean forward to drive additional power from your quadriceps muscles. Use the gearing to keep the same comfortable cadence you enjoy when riding on level ground.

Some ElliptiGO® products come equipped with bar extensions at the end of each handlebar. These extensions enable additional hand positions that can assist you to climb hills comfortably. They are not to be used when descending or riding on level ground. If you choose to use these extensions, you must realize that they position your hands further away from the brakes and shifters than when properly positioned on the grips. As a result, you will not be able to apply the brakes or shift gears when using the hand grips. Instead, you will need to reposition both hands to the hand grips before shifting or braking. This will take time and could prevent you from being able to avoid a collision in an emergency. As a result, only use the bar extensions when climbing and be extra cautious when using them. Never use the bar extensions when there are cars or other cyclists around because you will need immediate access to your brakes in case of an emergency. Once you have crested the hill, place both hands securely on the hand grips and continue riding as appropriate.

⚠️ WARNING! Always ensure both hands are securely positioned on the hand grips before braking. Braking with only one hand on the hand grips can cause the rider to lose control and suffer a fall.

As you crest the hill, shift up to accommodate your increase in speed while trying to keep the same cadence throughout.

When descending a hill, always make sure that you are traveling at a safe rate of speed. The preferred way to descend a hill is to “coast”. To coast, simply stop pedaling and stand on the foot platforms with your legs in a comfortable orientation. Use the brakes gently and frequently to control your speed. If you choose to pedal during a descent, make sure that you select the correct gear position (usually a “higher” gear) before starting to pedal. Pedaling while in an incorrect gear can cause the elliptical bike to become unstable, so always ensure you are in the correct gear for the speed you are traveling before pedaling. When in doubt, slow down to a more comfortable speed and shift into a higher gear before pedaling.

Riding in Adverse Conditions

⚠️ WARNING! Water on the road and in the air will reduce your ability to control and maneuver an elliptical bike. It also reduces the ability of motorists and other cyclists to control their vehicles. As a result, collisions and falls occur much more frequently in wet conditions. We strongly suggest not riding your bike when the roadways are wet. If you must ride, always use extreme caution, and allow for extra stopping distance and room to maneuver.

Riding in Wet Conditions

Riding in wet conditions subjects you to a significantly increased risk of serious injury or death as a result of a collision with a motor vehicle, cyclist, or stationary object or a fall. We recommend not riding ElliptiGO® products outside when the roads are wet, even if it isn't raining. This is because the contact between your tire and the road will cause moisture from the roads (and air) to be transferred onto your rims and significantly reduce the performance of your brakes and increase your stopping distance. In addition, the decreased friction between your tires and the road surface will reduce your ability to maneuver your bike and increase the chance that you will lose control while turning or stopping. This could result in a fall causing you serious injury or death. Finally, other cars and cyclists will experience similar effects, making it less likely that they will be able to see you and avoid colliding with you during an emergency.

If you must ride when it is wet out, always use extreme caution. Wear very bright and visible clothing, and use front and rear lights. Consider attaching lights or highly visible colors to your helmet. Travel at a slower speed and choose less traveled roads with wide bike lanes or bike paths where possible. In situations that require braking (e.g., when approaching a turn, stop light or stop sign), start applying the brakes very early so you can gauge how much stopping power you have given the reduction in friction between the brake pads and the rims. Take turns slowly and watch out for painted features on the roads.

These can become exceptionally slick when wet, so try to avoid them if possible.

Again, our strong recommendation is to avoid riding at all during wet conditions.

Riding at Night and During Periods of Low Visibility

⚠️ WARNING! Riding at night and during periods of low visibility significantly increases the likelihood of collisions and falls that can cause serious injury or death. Even with proper lighting, cyclists are difficult to see and are more likely to be struck by vehicles during periods of low visibility than during the day. In addition, dangerous road conditions are more difficult to spot and therefore, it is more likely that you will strike them. We strongly suggest not riding ElliptiGO products outside during periods of low visibility. If you must ride, always use lighting that complies with the laws in your area and ride with extreme caution.

Riding at night and during periods of low visibility significantly increases your risk of serious injury or death as a result of a collision with a motor vehicle, cyclist, or stationary object. We strongly recommend not riding bikes at night or during periods of low visibility. Even with proper lighting and highly-visible clothing, cyclists are difficult to see. In addition, dangerous road conditions are much more difficult to spot in time to avoid them at night and during other periods of reduced visibility which drastically increases the likelihood you will suffer a fall because of them. Although your elliptical bike is equipped with reflectors, they are not a substitute for the proper front and rear lighting systems. Always ensure you have proper lighting before choosing to ride at night.

▲WARNING! Reflectors are not substitutes for adequate front and rear lighting systems. Never ride at night or during periods of low visibility without front and rear lights that meet the requirements of your local laws. Because cyclists are difficult for drivers, pedestrians and other cyclists to see, riding without lights in these conditions is reckless and significantly increases the likelihood of collisions and falls that can cause serious injury or death.

▲WARNING! Do not remove the attached front and rear reflectors. They provide a valuable resource in alerting drivers and other cyclists that you are on the road and your direction of travel. Removing them will reduce your visibility when riding at all times, but especially during night and during periods of low light. This, in turn, will increase the chances that you will be struck by another vehicle while riding and be seriously injured or killed.

If you must ride at night or during other periods of reduced visibility, always use extreme caution. Always ride defensively, and make sure that drivers and other cyclists can easily predict any changes of speed or direction. Avoid abrupt stops or quick departures from your line of travel. Choose your path wisely, avoiding unlit or poorly lit roads, and including well-lit, low-traffic roads with wide bike lanes whenever possible.

Research the laws pertaining to night riding in your area and make sure that you comply with them, including having front and rear lights. Make sure that your lights provide enough visibility for you to see and be seen easily.

Wear light colored clothing and shoes that incorporate reflective materials into them; these can be purchased at most bicycle and running stores. Add lighted and/or reflective accessories to your body, especially on your arms and legs and helmet. When lit or seen by reflective materials, the motion of your legs will help attract attention and demonstrate that you are a moving object on the roadway that needs to be avoided. Take advantage of your body size to become as visible as possible on the road. The easier you make it to be seen, the less likely it is that you will be hit by a vehicle because the driver does not see you. Before riding, check to make sure that the faces of your reflectors are free from dirt and other obstructions, that the reflectors are securely attached to their mounts, and that the mounts are securely attached to your bike. If a reflector is damaged, replace it immediately. Also, make sure that your lights are working properly and bring a spare set of batteries. Check to ensure that your clothing or other objects will not obstruct your reflectors or lights. Again, if you do not absolutely have to ride at night, don't - the risks likely outweigh the benefits.

Competitive and Group Riding

Riding in groups or organized events, whether competitive or recreational, brings additional risks that must be addressed but cannot be eliminated. By choosing to ride in groups, in events, or in competitions, you are voluntarily assuming an increased risk of serious injury or death. As a result, it is imperative that you exercise additional caution. ElliptiGO products are designed to be used for exercise. If you choose to ride in events or competitions, we strongly encourage you to ride alone or with one other person and to always avoid large groups of cyclists. Before you ride

in an event with other cyclists, make sure that you have the experience and skill necessary to take on the added challenges of riding close to other cyclists. Choose your event wisely and get to know the course ahead of time to make sure there will be ample room for you to maneuver away from packs of cyclists.

▲WARNING! If you choose to ride in a cycling event, make sure to avoid riding in large groups of cyclists. ElliptiGO products are not designed to be ridden in a pack of cyclists and cyclists may inadvertently collide with the ElliptiGO bike's moving mechanisms - causing you and/or the cyclist to fall and suffer serious injury or death.

During competitive and recreational events, we strongly recommend against “drafting” behind other cyclists. Although drafting is a fundamental part of road biking, it is prohibited during elliptical biking events. The elliptical cyclist's riding position eliminates many of the benefits from drafting so the risks from being close to other cyclists far outweigh the benefits from any reduction in drag. Similarly, **never crouch down or change your body position to reduce your drag** while riding an ElliptiGO bike. This behavior will reduce your stability and increase the likelihood that you will crash or fall and suffer serious injury or be killed.

If you choose to compete in events that have one or more steep downhill sections, again, stay in an upright and well-balanced position at all times. We strongly recommend coasting downhill and using the brakes to maintain a safe speed. Even using these techniques, it is possible to reach speeds in excess of 40 mph. Traveling at that rate of speed

drastically increases the likelihood of serious injury or death during a fall.

▲WARNING! Even though you may have seen photographs or video footage of people riding ElliptiGO® products at high speeds, this does not indicate that this behavior is safe. Riding at high speeds is dangerous and can result in serious injury or death. Keep in mind that any high-speed maneuvers you may have seen were likely performed by professionals with extensive experience riding elliptical bikes. It is your responsibility to ride safely and within your abilities. Regardless of whether the riders in these photos or videos were using protective gear, always wear a helmet and protective clothing. Finally, it is essential that you understand that helmets and safety equipment can only reduce the amount of damage you suffer from a fall or crash - nothing can completely prevent injuries or death in every situation. As you increase your speed, the chances that your safety equipment will prevent serious injury or death should you crash or fall are reduced.

It is imperative that your bike be in top working condition before entering any event or ride that includes a steep descent. Do not use an ElliptiGO product that has any damaged parts or components. We recommend having your ElliptiGO bike carefully inspected by an ElliptiGO service expert or a trained bicycle mechanic who is familiar with the operation of the ElliptiGO bike and its components.

Stationary Trainers

Stationary trainers (also known as wind trainers or indoor trainers) are bike accessories that enable you to exercise on a bike without actually moving. There are a number of different stationary trainer manufacturers and your ElliptiGO bike will fit on many different models of trainers. The majority of trainers attach to bikes at the rear dropouts. Holding the frame fixed at the rear dropouts can put a significant amount of stress on the rear portion of the frame. That amount of stress created by using your bike in a stationary trainer will depend on your weight, how hard you ride, how long you ride, how often you ride and how you engage the foot platforms while riding in the stationary trainer.

The frames on ElliptiGO 3C, 8C, 8S and 11R models are robust enough to be used in a stationary trainer by people who weigh less than 250 pounds. However, the frame on the Arc model is not designed to be used in a stationary trainer and should not be used in one. Riding an Arc model in a stationary trainer voids your warranty and could irreparably damage your frame. It is possible that damage caused by riding the Arc model in a stationary trainer will introduce a crack into the frame that will cause the frame to fail when riding on the road. For more details about stationary trainers and a list of which stationary trainers we recommend for use with the 3C, 8C, 8S and 11R, please visit: www.elliptigo.com/trainer.

⚠ WARNING! DO NOT RIDE THE ELLIPTIGO ARC IN A STATIONARY TRAINER. Doing so voids your warranty and could cause significant damage to the frame which may

result in a frame failing during a ride. If your frame fails while riding you will likely lose control of your bike and suffer a fall.



Chapter 4: Service and Maintenance

Servicing ElliptiGO® Products

As with any piece of sophisticated equipment, your ElliptiGO elliptical bicycle will require periodic servicing and maintenance in addition to consistent inspections. All servicing beyond the routine maintenance steps discussed below should be performed by a professional bicycle mechanic or ElliptiGO-certified technician. To discourage you from attempting to service your ElliptiGO bike on your own, this manual does not provide any servicing procedures beyond routine maintenance.

Your maintenance and servicing requirements will depend on a number of factors, including your weight, the frequency, style and duration of your rides, the climate where you ride, and the condition of the surfaces upon which you ride. Regardless of how diligent you are with your inspections and careful you are when riding, your ElliptiGO bike components will fatigue with each ride and eventually they will wear out. Each component has a different lifespan and tolerance for abuse. Many can fail catastrophically without warning if subjected to the stresses of riding after they have reached the end of their life. Even a component that is covered by a warranty can fail before the expiration of its warranty depending on how it is affected by the factors listed above. Consequently, it is your responsibility to spot the signs of fatigue that can indicate when a component is reaching the end of its useful life and to have that component replaced by a professional bicycle mechanic or ElliptiGO-certified technician.

▲WARNING! Elliptical bicycles are subjected to high stresses during operation. Different materials and components may react to wear or stress fatigue in different ways. If the design life of a component has been exceeded, it may suddenly fail, possibly causing injuries to the rider. Any form of crack, scratches or change of coloring in highly stressed areas could indicate that the life of the component has been reached and it should be replaced.

We design ElliptiGO products so that all of the components work in concert to provide a safe and enjoyable riding experience. As a result, when you replace a safety-critical component, always use a genuine replacement part. If you replace an original component with a different component, the change can have a ripple effect through the entire system and potentially put additional stress on other components. This additional stress could cause the new component or the existing components to wear out more quickly or, depending on the nature of the new component, could result in a catastrophic failure of a component during normal use.

While servicing of the ElliptiGO bike should be done by a professional bicycle mechanic, you should perform the following routine maintenance and inspections before and after every ride.

Routine Maintenance and Inspections

1. Before every ride:

- a. Execute the Pre-Ride Safety Checklist. This is a critical process for ensuring your elliptical cycle is in good working order and it is the best way to prevent an injury caused by a worn out or improperly operating component.
- b. If your elliptical bike has guide tracks, wipe them down with a soft, dry cloth and inspect the load wheels for cracks. Remove any debris left on the tracks and if a load wheel is cracked, DO NOT RIDE. Instead, have the load wheel replaced.

2. After every ride:

- a. Wipe the bike down, inspecting it for damage and loose cables or components. Pay particular attention to the load wheels (if any), rims and brakes, examining the load wheels for cracks, the rims for cracking or bowing and the brakes for proper adjustment, alignment, and sufficient brake pad depth. Address any issues you find.
- b. Take time to thoroughly inspect the drive arms and swing arms (if any) to make sure there is no visible damage to them.
- c. Test the headset and steering column to make sure they are tightened properly. Straddle the bike and pull on the front brake lever to lock the front wheel. With the front wheel held by the front brake, push forward on the handlebars so that the rear wheel lifts off the ground, then drop the wheel back down, feeling for movement through the steering column and headset. If there is movement, check the tightness of the steering column quick release systems. If

they are appropriately tight, then the headset may be loose. Take your elliptical bike to a professional bike mechanic to have him or her examine the headset.

- d. Do a thorough inspection of the spokes on both wheels. They should all feel equally tight. If any one feels looser than the others, take your elliptical bike to a professional bicycle mechanic to have the spokes tightened and the wheel trued.
- e. If your elliptical bike has a track system, then wipe down the guide tracks with a soft, dry cloth. Inspect the tracks for debris and the load wheels for cracks and debris. If the load wheels are cracked, have them replaced before your next ride. If the load wheels or tracks have accumulated debris, remove the debris.
- f. If you encountered any moisture during the ride, such as puddles, rain or wet roads, ensure that the bike is completely dry before you put it away and lubricate the chain with oil.

If during your pre- or post-ride inspections you see any frayed, scratched, torn, damaged or discolored component, cable, housing, or part, take your ElliptiGO cycle to a professional bicycle mechanic or ElliptiGO-certified technician to have it inspected and the part replaced.

⚠️ WARNING! Always have a professional bicycle mechanic or ElliptiGO-certified technician service your elliptical bike. Failure to properly service your bike can result in the improper functioning of one or more components during a ride, causing the rider to suffer a fall. Improper servicing can also result in damage to the ElliptiGO elliptical cycle and could void your warranty.

Maintenance Chart

The appropriate maintenance intervals for your ElliptiGO® elliptical bicycle depend on many variables, including your weight, riding style, riding terrain and riding environment. The recommendations below are based on a 175-pound rider riding about 75 miles per week (300 miles per month) on relatively flat, well-paved surfaces in a mild climate. This chart assumes that the pre-ride and post-ride inspections and wipe-down described in the Owner's Manual are being done consistently. Those activities are critical for identifying parts that are wearing more quickly than expected or have been damaged during riding. Proper maintenance is an important part of a safe cycling experience, so we highly recommend performing regular maintenance on your elliptical bike.

	Every Ride	Every Month	3 Months	6 Months	9 Months	12 Months	15 Months	18 Months	21 Months	24 Months
Inflate Tires ♦	x									
Wipe Track Inserts and Load Wheels ±	x									
Lube Chain ♦		x								
Professional Tune-Up ±						x				x
Adjust Chain Tension ±			x	x	x	x	x	x	x	x
Replace Brake Pads ♦						x				x
Replace Shifter and Brake Cable ±						x				x
Replace Cable Housing ±						x				x
11-speed Hub Oil Change ±			x							x
8-speed Hub Maintenance ±										x
Replace Track Inserts and Load Wheels ±						x				x
Replace Tires ♦						x				x
Replace Chainring and Cassette*										x
Replace Chain ±						x				x
Replace Rear Derailleur Jockey Wheels*										x

♦ All ElliptiGO Bikes

± Long Stride Bikes Only (3C, 8C, 8S, 11R)

* Compact Stride Bikes Only (Arc)

What Happens if I Damage My Bike?

If you damage your bike by colliding with another object or sustaining a fall, first ensure that you do not require medical attention. If you do, get medical help immediately.

Even if you are unhurt, DO NOT RESUME RIDING your bike. Instead, take it to a professional bike mechanic or to an ElliptiGO® Certified Technician. Do not resume riding the bike until a professional has thoroughly checked out the entire system and taken it for a test ride.

How Long Will My Bike Last?

The short answer is: we don't know exactly how long your ElliptiGO elliptical bike will last, but we do know that it will not last forever.

As discussed above, the lifespan of any given component on your bike varies with a range of factors, including rider weight, frequency of riding, duration of rides, riding surface, intensity of riding, style of riding, climactic conditions when riding and in storage, and diligence with maintenance and servicing.

Because it is impossible to predict exactly how long any given component will remain serviceable, it is important for you to be able to spot the signs of component aging so you can avoid experiencing a catastrophic failure of a component that is beyond its useful service life. What is equally important for you to know is that some components can show no signs of stress or damage before giving out, so it is critical to have a professional bicycle

mechanic or ElliptiGO-certified technician inspect your elliptical bike periodically to ensure everything is in good working order.

We recommend having your ElliptiGO elliptical cycle inspected by a professional after every 50 hours of riding if you are an average weight rider (175 pounds) using the bike for exercise on well-maintained paved roads and average around 12-15 mph when riding. That's about every 10 weeks if you ride an hour a day, five days a week. If you are a heavier rider, frequently engage in aggressive climbing and descending, or ride on poorly maintained roads, you should have your ElliptiGO bike checked more frequently. Again, you should inspect the bike before and after every ride, the 50 hour rule of thumb is for periodic inspections by a professional.

These professional inspections can be critical for identifying failing parts early so you can avoid the extreme hazards that accompany a catastrophic failure of a component during use. A professional technician will be very familiar with the operation of almost all of the components on your elliptical bike and be able to spot damage or accelerated aging more easily than someone who is untrained in bicycle mechanics. This is why they can identify problems early-on and then advise you regarding the best way to handle them.

At the end of the day, like most things in life, your safety and experience with the ElliptiGO bike are in your hands. When used properly, your cycle will provide you with many years of enjoyable outdoor low-impact exercise. If you pay

attention to the bike and its components, keep them clean and in good working condition, inspect them before and after each ride, and have your bike inspected frequently by a professional, you should be able to derive the full value from the machine. If you neglect to maintain the bike, rarely inspect the components, fail to keep the bike clean and the drive train lubricated, or pay no attention to signs of damage or excessive wear, you will likely experience problems with your elliptical bike and could experience a catastrophic failure of a component while riding.

ELLIPTIGO® Bikes with Composite Drive Arms

As discussed above, we have designed your elliptical cycle to provide a high-performance exercise experience. There are many considerations that went into creating your bike, including safety, weight, stiffness, ride comfort, and aesthetics. We chose to construct the drive arms on some of our models from a composite material called “carbon fiber” because of the superior stiffness to weight ratio this material delivers as compared to metals such as steel, aluminum, and titanium. However, there are some significant differences you should be aware of regarding how composites like carbon fiber behave as compared to metals.

The biggest difference between the behavior of carbon fiber and common metals during periods of extreme stress is that metals tend to bend or deform before they break, often providing a warning sign that a metal part has been overly fatigued. Carbon fiber parts, on the other hand, neither bend nor deform prior to breaking. When overloaded beyond their capacity, they will often just snap

in a single catastrophic failure. This is important for you to understand because the drive arms are the things you are standing on when you ride your elliptical bike and if one of them breaks, you will almost certainly suffer a fall and be seriously injured or killed.

The drive arms have been designed to withstand the fatigue associated with their intended use by a rider who weighs less than 250 pounds fully-laden. If you misuse the bike, collide with another object, or are involved in a crash, you can damage the drive arms to the point of breaking them. Although breaking your drive arms is bad, damaging them without breaking them could be even worse because a damaged drive arm can catastrophically fail during regular use without warning. Consequently, you must be on the lookout for signs that your drive arms are damaged so you can replace them and avoid serious injury or death from a drive arm failure during normal use.

Damaged carbon fiber can be identified by observing visual signs of cracking or delamination, hearing creaking or other noises when the carbon fiber flexes, or feeling a lack of stiffness in the part.

Cracks

Cracks can come in any size, but regardless of how small a crack is, you should not ride an elliptical bike with a crack in the drive arm. Once a crack has formed it will continue to grow and splinter over time and use, eventually resulting in a catastrophic failure of the part. Cracks can be found during a thorough visual inspection of the drive arms. Pay particular attention

to the sections of drive arm immediately in front of and behind the foot platforms, as these are the areas under the greatest amount of stress during operation.

Again, never ride on a drive arm that has a crack, regardless of the size. Instead, contact service@elliptigo.com for a replacement drive arm.

Delamination

Your carbon fiber drive arm is comprised of several thin layers of carbon fibers bonded together by epoxy. Delamination describes the condition where the carbon fiber layers separate from each other.

Delamination can have a number of causes, many of which do not require abusing the part. Regardless of why the delamination occurred in the first place, the result is that it can greatly reduce the strength of the part and put the rider at risk of an unexpected catastrophic failure that can result in serious injury or death. Consequently, you should never ride on a drive arm or other component that shows signs of delamination. Instead, contact service@elliptigo.com for a replacement drive arm, or your component dealer for a replacement component.

There are several different visual indicators that can be signs of delamination. The most common sign of delamination is a cloudy discolored area forming on the surface of the part. Undamaged carbon fiber should appear glossy black or gray. Examine your new drive arms to get a good picture of what undamaged

carbon fiber looks like. If an area on your drive arm begins to look cloudy, this is a sign of delamination.

The second most common visual sign of delamination is slight deformations in the part itself. When you receive your elliptical bike, inspect it so you can become familiar with the smooth lines of the drive arms. During your regular inspections, pay attention to these lines to see if there has been any change to them, especially a single bulge, bump or depression in the part. If you find something unusual this could be a sign of delamination. Before riding, take your bike to a professional bicycle mechanic or ElliptiGO®-certified technician for inspection. When in doubt, contact service@elliptigo.com for a replacement drive arm.

In addition to visual signs, there are audible indicators of delamination. When riding listen for any creaking or popping sounds coming from the drive arms. Your drive arms should be quiet. If a drive arm is creaking under load, this is a strong indicator that it is damaged and could fail catastrophically during normal operation. Even if you can't see any signs of delamination or cracking, a creaking drive arm must be replaced. In that case, do not ride. Instead, contact service@elliptigo.com immediately for a replacement drive arm.

Finally, when inspecting your drive arms, use your fingernail to strike the carbon fiber at regular intervals and listen to the sound it generates. It should be a nice, sharp sound every time you strike the surface. If one area returns a different sound, especially one that is muted or dull, this is an indicator that delamination is occurring inside the part. Take your ElliptiGO bike to a professional bicycle mechanic or ElliptiGO-certified technician for further evaluation.

Torque Requirements for Screws and Fasteners on 3C, 8C, 8S and 11R Models

Item	Fastener Location / Description	Fastener Size	Tool Required	Qty	Torque (N-m)
1	Ergon GC3 Integral bar-end Grips to Handlebars (On Certain Models Only)	M6x1.0	5mm allen	2	8
2	Gear Shifter to Handlebars	M6x1.0	5mm allen	1	5-7
3	Brake Levers to Handlebars	M5x0.8	4mm allen	2	4-5
4	Stem to Handlebars	M5x0.8	4mm allen	4	4-5
5	Steering Extender Star Nut	M6x1.0	5mm allen	1	6-8
6	Stem to Steering Extender	M6x1.0	5mm allen	2	8-10
7	Steering Column Base to Fork Steering Tube	M6x1.0	5mm allen	2	6-8
8	Track Inserts to Frame - TIGHTEN VERY LIGHTLY TO AVOID STRIPPING!	M3x.5	2.5mm allen	8	0.8-1.0
9	Kickstand to Frame	M6x1.0	5mm allen	2	6-8
10	Rear Brakes to Frame	M6x1.0	5mm allen	2	5-7
11	Front Brakes to Fork	M6x1.0	5mm allen	2	5-7
12	Brake Pads to Brake Arms	M6x1.0	5mm allen	4	6-8
13	Brake Cable to Brake Arms (Cable Anchor Bolt)	M6x1.0	5mm allen	2	6-8
14	Bottom Bracket to Frame	1.37"-24	BB Tool	2	50-70
15	RH & LH Crank to Bottom Bracket	M15x1	8mm allen	2	47-54
16	Chainring/Chain guard to RH Crank	M8x0.75	6mm allen	5	8-10
17	Drive Arm Axle to RH Crank Arm	9/16"-20 RH	6mm allen	1	34
18	Drive Arm Axle to LH Crank Arm	9/16"-20 LH	6mm allen	1	34
19	Crank Axle Retention Screw to RH Crank Arm - TIGHTEN VERY LIGHTLY TO AVOID STRIPPING HEX!	M6x1.0 LH	2.5mm allen	1	2
20	Crank Axle Retention Screw to LH Crank Arm - TIGHTEN VERY LIGHTLY TO AVOID STRIPPING HEX!	M6x1.0 RH	2.5mm allen	1	2
21	Drive Arm Bearing Adjustment Screw to RH Axle (Under GO Cap)	Set at Factory !! DO NOT TIGHTEN !!			
22	Drive Arm Bearing Adjustment Screw to LH Axle (Under GO Cap)	Set at Factory !! DO NOT TIGHTEN !!			
23	Drive Arm Foot Basket to Drive Arm Body (Aluminum Drive Arms only)	M6x1.0	4mm allen	16	8
24	Chain Tensioner to Dropout	M4x.7	3 mm allen	4	2-3
25	Chain Tensioner Bolt	M6x1.0	5mm allen	2	5-7
26	Shifter Cable Inner Cable Fixing Bolt	-	wrenches	1	3
27	Rear Wheel Axle Nuts to Frame	3/8"	15mm wrench	2	30

Torque Requirements For Screws And Fasteners - Arc Model

Item	Fastener Location / Description	Fastener Size	Tool Required	Qty	Torque (N-m)
1	Grips to Handlebars	M4x0.70	3mm allen	2	2-3
2	Gear Shifter to Handlebars	M6x1.0	5mm allen	1	5-7
3	Brake Levers to Handlebars	M5x0.8	4mm allen	2	4-5
4	Stem to Handlebars	M5x0.8	4mm allen	4	4-5
5	Steering Extender Star Nut	M6x1.0	5mm allen	1	6-8
6	Stem to Steering Extender	M6x1.0	6mm allen	2	8-10
7	Steering Column Base to Fork Steering Tube	M6x1.0	5mm allen	2	6-8
8	Kickstand to Frame	M6x1.0	4mm allen	2	6-8
9	Rear Brakes to Frame	M6x1.0	5mm allen	2	5-7
10	Front Brakes to Fork	M6x1.0	5mm allen	2	5-7
11	Brake Pads to Brake Arms	M6x1.0	5mm allen	4	6-8
12	Brake Cable to Brake Arms (Cable Anchor Bolt)	M6x1.0	5mm allen	2	6-8
13	Swing Arm Axle to RH Frame Tube	9/16"-20 RH	15mm open end	1	34
14	Swing Arm Axle to LH Frame Tube	9/16"-20 LH	15mm open end	1	34
15	Swing Arm Axle Screw to RH Swing Arm Axle (Under GO Cap)	M6x1.0 LH	4mm allen	1	6-8
16	Swing Arm Axle Screw to LH Swing Arm Axle (Under GO Cap)	M6x1.0 RH	4mm allen	1	6-8
17	Swing Arm Clevis to Axle	M6x1.0	4mm allen	2	6-8
18	Foot Platform Pivot Bracket to Drive Arm	M6x1.0	4mm allen	8	4-5
19	Foot Platform Pivot Axle to Foot Platform Bracket	M6x1.0	4mm allen	2	6-8
20	Foot Platform to Foot Platform Bracket	M6x1.0	4mm allen	8	5-6
21	Bottom Bracket to Frame	1.375" -24	BB Tool	2	50-70
22	RH/LH Crank to Bottom Bracket	M15x1	8mm allen	2	47-54
23	Chainring /Chain guard to RH Crank	M8x0.75	5mm allen	5	8-10
24	Chain Keeper Bracket to Frame	M6x1.0	4mm allen	1	6-8
25	Chain Keeper to Chain Keeper Bracket	M5x.8.0	3mm allen	1	4-5
26	Drive Arm Axle to RH Crank Arm	9/16"-20 RH	6mm allen	1	34
27	Drive Arm Axle to LH Crank Arm	9/16"-20 LH	6mm allen	1	34
28	Crank Axle Screw to RH Drive Arm Axle (Under GO Cap)	M6x1.0 LH	4mm allen	1	6-8
29	Crank Axle Screw to LH Drive Arm Axle (Under GO Cap)	M6x1.0 RH	4mm allen	1	6-8
30	Cassette Lock Ring	-	Shimano Lock Ring Tool	1	30-50
31	Shifter Cable Inner Cable Fixing Bolt	M6x1.0	5mm allen	1	6-8
32	Derailier Hanger to Frame	M4x0.70	3mm allen	2	2-3
33	Derailier to Hanger	M10x1.0	5mm allen	1	8-10

Satisfaction Guarantee

We guarantee that you will love your ElliptiGO® elliptical bicycle. If you purchased your bike directly from ElliptiGO Inc., you can return it for any reason within 30 days of purchase for a full refund, less return shipping charges, if any. It is your responsibility to retain all original packing materials so they can be used in the event of a product return. Any item that is damaged or is missing parts for reasons not due to our error may receive a partial refund, which would be communicated upon receipt of the return. Just contact us at service@elliptigo.com to arrange the return and we will send you more details.

If you purchased from an authorized dealer, that dealer's return policy will apply instead.

Limited Warranty

We also guarantee that your ElliptiGO elliptical cycle will be free from manufacturing defects for the periods stated below:

- Five years: Frame
- Two years: Fork, Drive Arms, Crank Arms, and Steering Column
- One year: All Other Components, Paint and Decals

This is the only warranty for your ElliptiGO bike and it is limited to the initial purchaser (it expires upon resale or transfer of the product to another party). The warranty applies only to products purchased from ElliptiGO Inc. directly or from an authorized dealer.

During the term of this warranty, if you experience a defect in your ElliptiGO bicycle, we will either repair

or replace the defective part free of charge. This warranty does not cover any costs for return shipping, labor installation, transportation or any other expenses incurred because of the defective part.

Limits to Coverage

This warranty does not cover damage to your elliptical bicycle resulting from:

- Normal wear and tear
- Improper use (see Owner's Manual for a detailed discussion of proper and improper use of the ElliptiGO)
- Improper assembly of a component or the bike itself performed by someone other than an authorized representative of ElliptiGO
- Improper servicing of a part by someone not authorized by ElliptiGO
- Failure to perform routine maintenance
- The use of parts other than the original parts or replacement parts purchased from ElliptiGO
- Collisions, crashes, or physical abuse to the bike
- Neglect or use of the ElliptiGO elliptical bike when in a state of disrepair

Note that tires, tubes, brake pads, load wheels, track inserts and other wear parts will require replacement over time and are only covered by this warranty for manufacturer's defects.

Voiding Your Warranty

You void your warranty by:

- Misusing the bike (see your Owner's Manual for a

detailed discussion of proper and improper uses of the ElliptiGO® bike)

- Exceeding the rider weight limit of 250 pounds
- Making any modification to the ElliptiGO bike frame
- Making any modification to the ElliptiGO bike components

Claims

To make a claim through this warranty, please contact service@elliptigo.com.

Subject to the laws of the governing jurisdiction, ElliptiGO shall not be responsible for any incidental or consequential damages arising from this offer of warranty or that result directly or indirectly from the use of ElliptiGO products.

Your rights under this warranty are limited to the reparation or replacement of your product. The decision to repair or replace resides solely with ElliptiGO. This warranty affords you certain rights that vary by jurisdiction. Any limitations expressed in this warranty do not affect your statutory rights under the law of the relevant jurisdiction.

If a court of competent jurisdiction determines that one or more specific provisions contained in this limited warranty cannot be applied, the inapplicability of that provision shall not affect the enforceability of any other provision contained herein and all other provisions shall remain in full effect for the term of the warranty

Notes

ELLIPTIGO®